

INSTALLATION INSTRUCTIONS

HONDA CRV 2012

PART LIST				
ITEM	QTY	CODE	DESCRIPTION	MAX.TROQUE
	1	BRK-3913945	BRACKETS KIT:	
1	1		FROUNT MOUNTING BRACKET SET	
2	1		REAR MOUNTING BRACKET SET	
3	2		1/2" BOLT PLATE	
4	6		3/8" BOLT PLATE	
	1	KTE-3913945	HARDWARE KIT :	
5	2		1/2" FLAT WASHER	
6	2		1/2" LOCK WASHER	
7	2		1/2" HEX NUT	55Lb.FT
8	2		3/8 X1" HEX HEAD BOLT	30Lb.FT
9	8		3/8" FLAT WASHER	
10	8		3/8" LOCK WASHER	
11	8		3/8" HEX NUT	30Lb. FT
12	12		5/16" SQUARE HEAD BOLT	11 Lb. FT
13	12		5/16" FLAT WASHER	
14	12		5/16"LOCK WASHER	
15	2		M6X30mm HEX HEAD BOLT	9Lb.FT
16	2		M6FLAT WASHER	
17	2		M6 LOCK WASHER	

REQUIRED TOOLS (NOT INCLUDED)	
QTY	DESCRIPTION
1	3/4" SOCKET / WRENCH
1	12mm SOCKET / WRENCH
1	9/16" SOCKET / WRENCH
1	10mm SOCKET / WRENCH
1	17 mm SOCKET (12POINT) OR 15mm WRENCH
1	RATCHET W/ EXTENSION

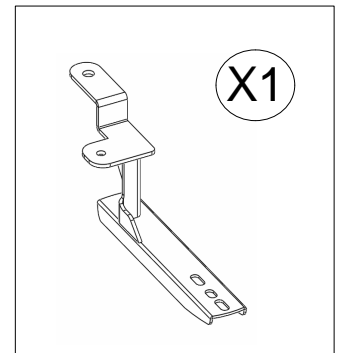
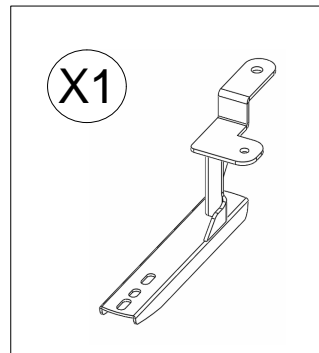
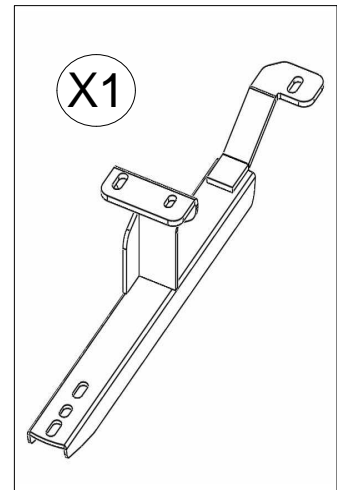
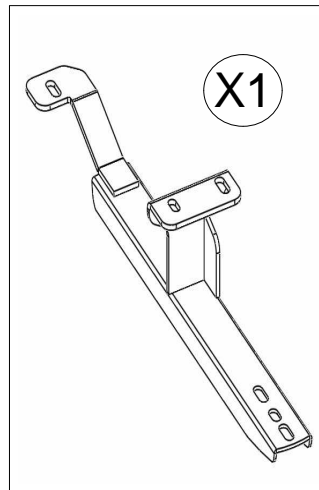

INSTRUCTIONS

BEFORE BEGINNING THE INSTALLATION, READ ALL THE INSTRUCTIONS THROUGHTLY AND VERIFY THAT ALL THE HARDWARE IS ACCOUNTED FOR. IF THERE ARE ANY LISTED PARTS MISSING, PLEASE NOTIFY YOUR DISTRIBUTOR IMMEDIATELY.

THE APPROXIMATE INSTALLATION TIME IS: 30min.

1. Begin by installing the driver side front bracket. Locate and remove the rubber plug to expose the hole and the M6 bolt. Securing the plastic shroud to the underside of the body. Picture 1
2. Insert one of the 3/8" bolt plates into the hole where the plug was removed, and secure the front mounting bracket to the Body using the 3/8" bolt plate, (1) 3/8" flat washer, (1) lock washer and (1) 3/8" hex nut and to the threaded hole using (1) M6 hex bolt, (1) M6 flat washer and (1) M6 lock washer. Leave the bolt and nut loose for final adjustment. Picture 2.

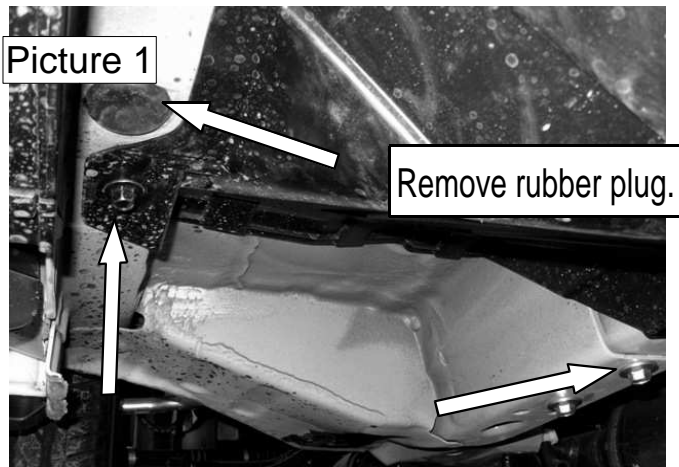

Remove these bolts.
Driver side shown.

Bracket delantero, lado
conductor

Locate the (2) bolts at the front of the frame, and remove the bolt toward the rear of the vehicle, secure the driver side auxiliary part of The front bracket. Picture 3

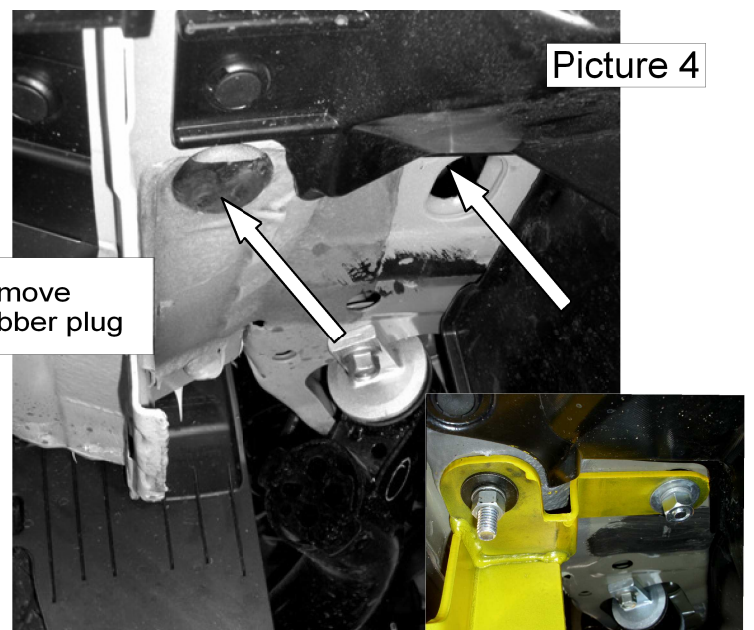
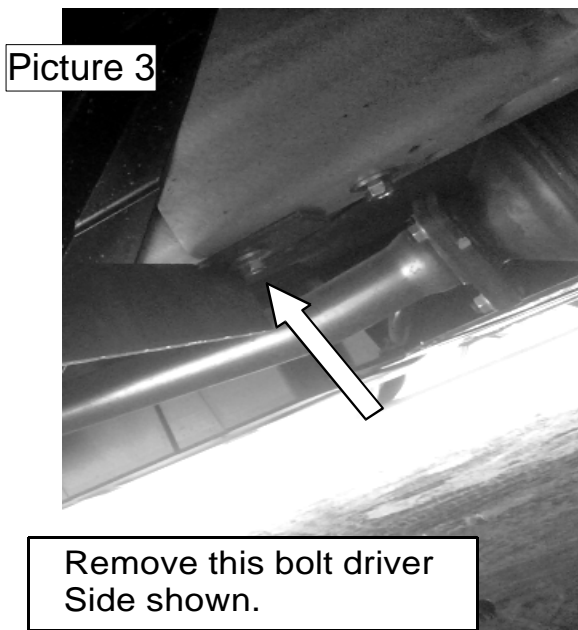

3. To install the rear mounting bracket, locate the obround hole and remove the rubber plug to expose the hole in the underside of the body at the rear of the vehicle. Picture 5

Insert one of the 1/2" bolt plates into the obround hole and one of the 3/8" bolt plates into the hole where the plug was removed. Secure the rear mounting bracket to the body using the 3/8" and 1/2" bolt plates, flat washers, lock washers and hex nuts. Leave the nuts loose for the final adjustment.

4. Repeat the all the steps for the other side of the vehicle.

5. Place the driver side step on top of the mountign brackets. Position (2) of the "u" brackets (included with The side step) inside the step body, and align the U- brackets whit the mounting brackets. Attach the side Step and U-brackets to each mounting bracket using (2) 5/16" square head bolts, (2) 5/16" flat washers and (2) 5/16" lock washers. Image 1

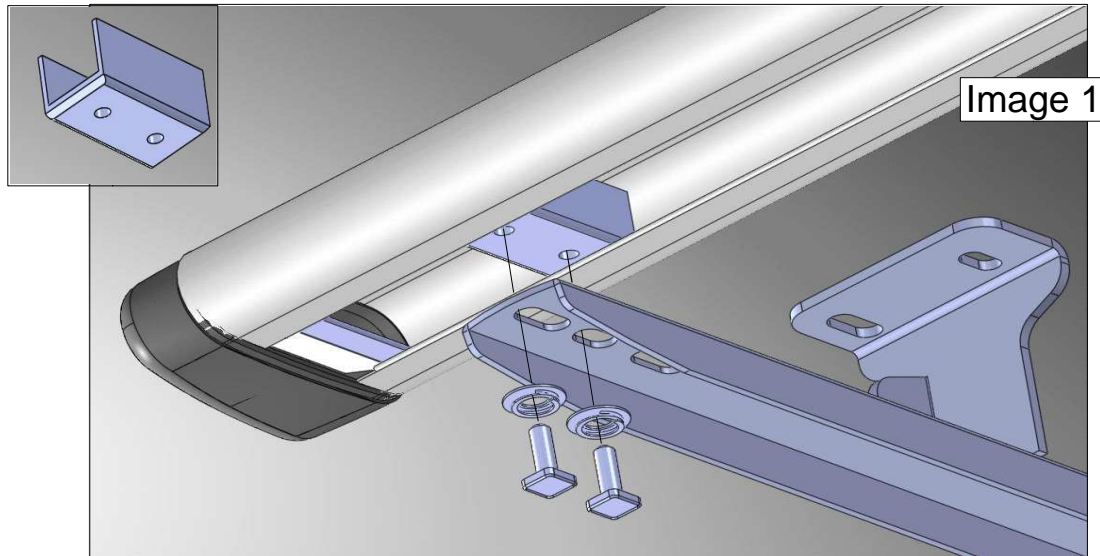

8. Align the side step with the vehicle an thigten the mounting brackets and the side step nuts and bolts. Remember to periodically check and retighten all nuts and bolts.
To maintain and care this product keep it clean and do not use abrasive cleaners

