

INSTALLATION INSTRUCTIONS

Wheel to Wheel

Chevrolet Silverado / GMC Sierra 2500HD, 3500HD Crew Cab 6.5' Bed

2015

37304

PARTS LIST

Item	Qty.	Part No.	Description	Torque
1	1	37304	WHEEL TO WHEEL PASSENGER SIDE	
2	1		WHEEL TO WHEEL DRIVER SIDE	
3	2	376012AA	FRONT BRACKET	
4	2	376014AA	CENTER BRACKET	
5	1 set	376012BA	REAR BRACKET	
6	2		3/8 X 8 1/4" THREADED STUD	30 Ft Lbs
7	2		3/8" X 1 1/4" HEX BOLT	30 Ft Lbs
8	8		3/8" FLAT WASHER	
9	6		3/8" LOCK WASHER	
10	2		3/8" LOCK NUT	
11	4		3/8" HEX NUT	
12	2		RUBBER BUSHING	
13	4		1/2" X 2" HEX BOLT	70 Ft Lbs
14	10		1/2" FLAT WASHER	
15	10		1/2" LOCK WASHER	
16	6		M12 X 120MM HEX BOLT	75 Ft Lbs

Illustration 1

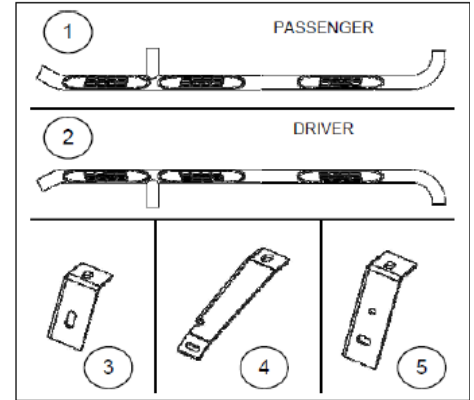

**Tool Required:**

- A. 9/16", 3/4" & 21mm Wrench
- B. Ratchet
- C. Ratchet extension
- D. 9/16", 3/4" & 21mm socket

Before beginning the installation read all instructions thoroughly and verify that all hardware is accounted for. If there are any listed parts missing, please notify your distributor immediately.

To maintain and care this product keep it clean and do not use abrasive cleaners or polish waxes. It is recommended to use only non-abrasive automotive wax such as pure carnauba to avoid scratches and rust.

**WARNING!** GM uses thread-locking compound on all factory body mount bolts. Removal using an air assisted impact or ratchet will damage the body mount bolt threads and the internal nut assembly.

We only recommend using hand tools to slowly remove and reinstall body mount bolts on all GM vehicles.

**IMPORTANT!** If during the body mount bolt removal process, it becomes increasingly difficult to unscrew the bolt with hand tools, tighten the bolt several rotations to clear the thread-locking compound from the threads, then reverse the direction and continue to unscrew the bolt until it is out. Repeat this process as necessary on all of the body mount bolts. Use of an appropriate anti-seize compound is highly recommended for re-installation. Tighten the body mount bolts to factory torque specifications.

The wheel to wheel set consists of a driver and passenger side. (Illustration 2).

ILLUSTRATION 2

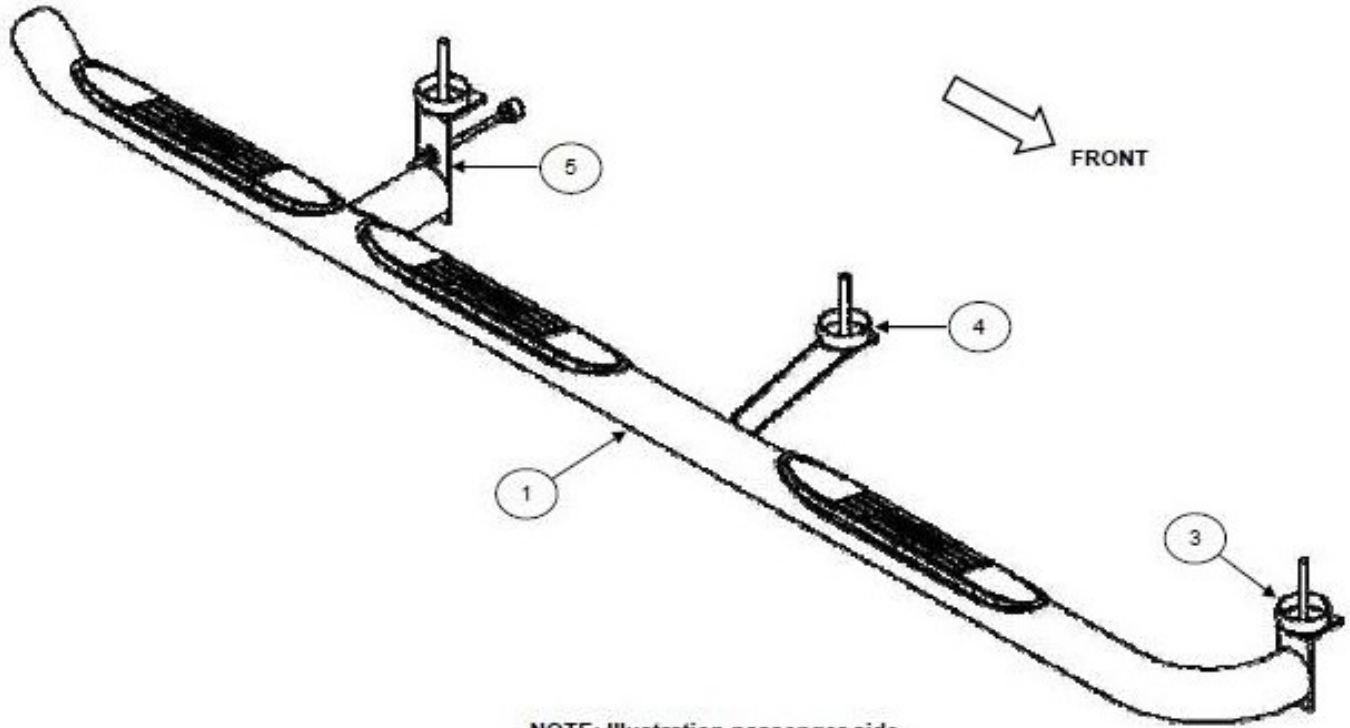

NOTE: Illustration passenger side.

1. Begin the installation by removing the passenger side front, middle and rear body mount bolts. Keep all existing washers and bushing in place, and attach the front, middle and rear brackets to the vehicle using the factory body mount bolt. Leave the bolts loose for final adjustment. **(Illustration 3)**. **NOTE:** If the factory bolts removed are short, attach using: ( 1 ) M12 x 120mm hex head bolts, ( 1 ) 1/2" flat and lock washers.
2. Assemble the threaded stud, nuts, washers and rubber bushing on the rear bracket. **(Illustration 3)**.
3. Attach the passenger side wheel to wheel to the front and rear brackets using (1) 1/2 x 2" hex bolt, (1) 1/2" lock washer and (1) 1/2" flat washer. **(Illustration 3)**.
4. Attach the passenger side wheel to wheel to the middle bracket using (1) 3/8 x 1 1/4" hex bolt, (1) 3/8" lock washer and (1) 3/8" flat washer. **(Illustration 3)**.

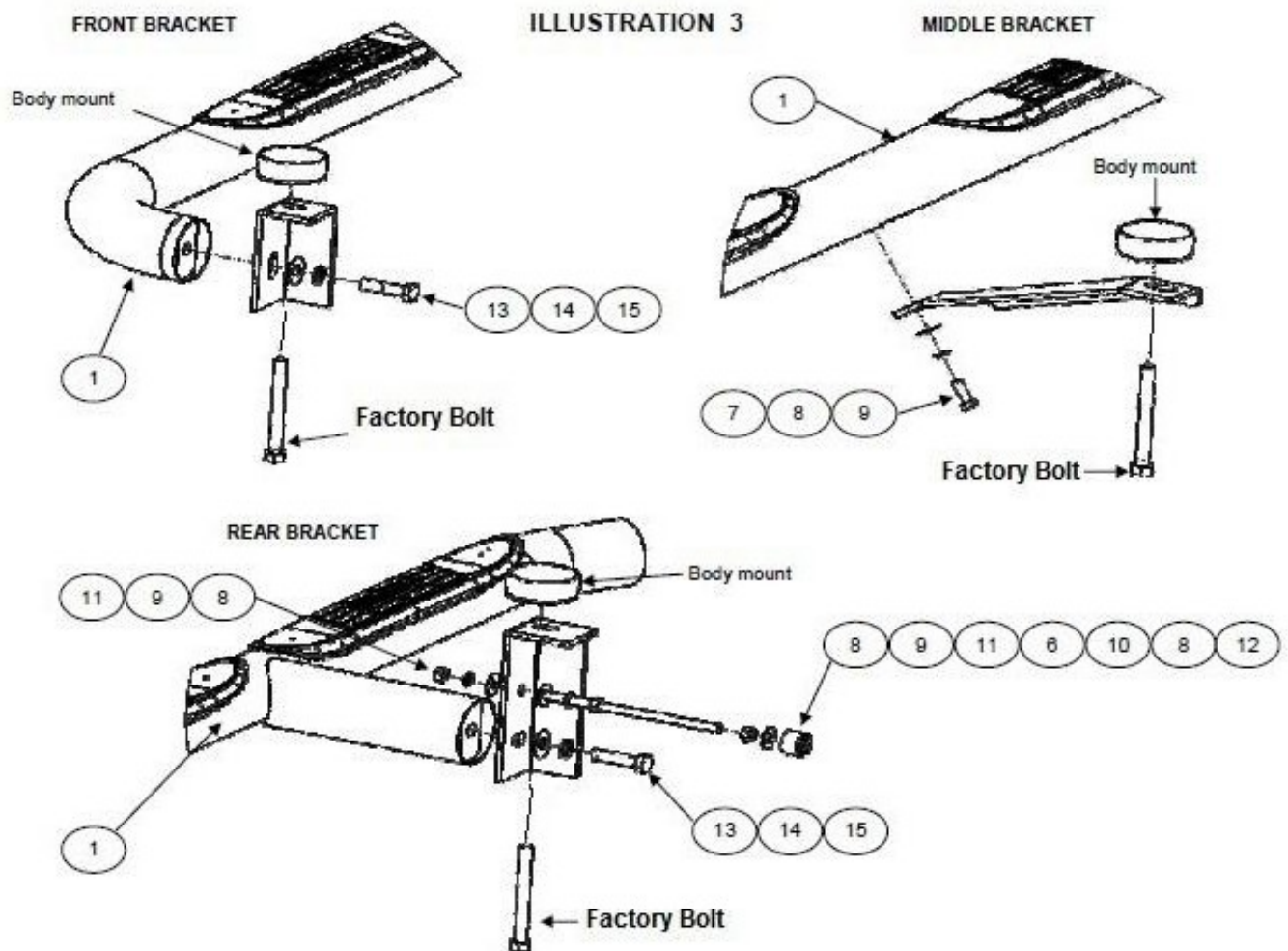

5. Align the wheel to wheel with the vehicle and tighten all wheel to wheel and brackets nuts and bolts.
6. Adjust and tighten the threaded stud and rubber bushing assembly so that the rubber bushing is firm against the side of the frame.
7. Repeat the installation steps to install the driver side brackets and wheel to wheel. Remember to check and retighten all nuts and bolts periodically.