

INSTALLATION INSTRUCTIONS
503331 FRONT MODULAR EUROGUARD
503334 FRONT S.S. EUROGUARD / 503335 FRONT ONE PIECE EUROGUARD
FORD F-150 / LOBO (INCL. ECOBOOST) 2009 - 2012

Parts List:
QTY

1 EUROGUARD	4 1/2" HEX NUT Z.P.
2 LOWER BRACKET	4 1/2" LOCK WASHER Z.P.
2 UPPER BRACKET	2 3/8x1 1/4" CARRIAGE HEAD BOLT B.P.
2 AUXILIARY UPPER BRACKET	2 3/8" FLAT WASHER B.P.
2 "T" BOLTS	2 3/8" LOCK NUT B.P.
4 TAB BOLTS	2 3/8x1" CARRIAGE HEAD BOLT Z.P.
1 Hardware kit KTE-50333	4 3/8" FLAT WASHER Z.P.
2 VINYL GASKETS	4 3/8" LOCK WASHER Z.P.
1 WIRE GUIDE	4 3/8" HEX NUT Z.P.
4 1/2x1 1/4" CARRIAGE HEAD BOLT B.F	2 M8-1.25x40 HEX HEAD BOLT B.P.
4 1/2" FLAT WASHER B.P.	2 1/4" FLAT WASHER B.P.
4 1/2" LOCK NUT B.P.	
4 1/2" FLAT WASHER Z.P.	

Modular Euroguard includes extra:

2 BRUSHGUARD SET
4 3/8x1 1/4" ALLEN HEAD BOLT
4 3/8" FLAT WASHER
4 3/8" LOCK NUT
2 FLAT RUBBER GASKET

Tools required:

15MM SOCKET	3/4" SOCKET	13MM SOCKET	RATCHET
10MM SOCKET	9/16" SOCKET	CUTTER	

Modular Euroguard requires extra:

7/32" ALLEN WRENCH

Instructions:

Approximated installation time: 40 min.

1. Before beginning installation, please read all directions carefully and verify all necessary hardware is accounted for. If any parts are missing, stop the installation and contact your distributor.

2. If vehicle has **tow hooks** proceed to remove the bolt located toward the front of the vehicle and loosen the rear bolt. See **Img. 1**. **If vehicle does not have tow hooks** follow step 4.

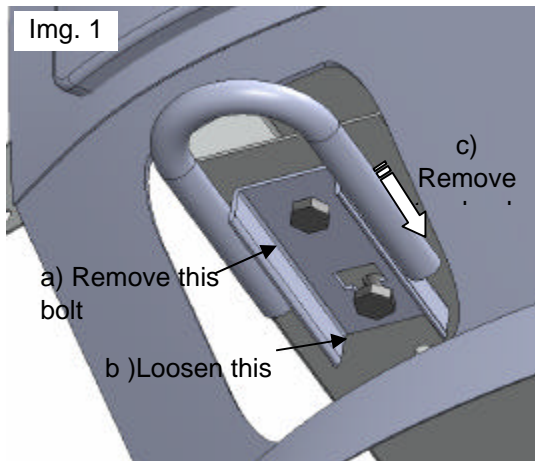

3. **Place lower bracket over** the exposed tow hook bolt and re-install the tow hook over the Euroguard bracket. **Re-install** using the original equipment bolts removed in step 2. **Img. 2**. Leave loose. **Follow step 8.**

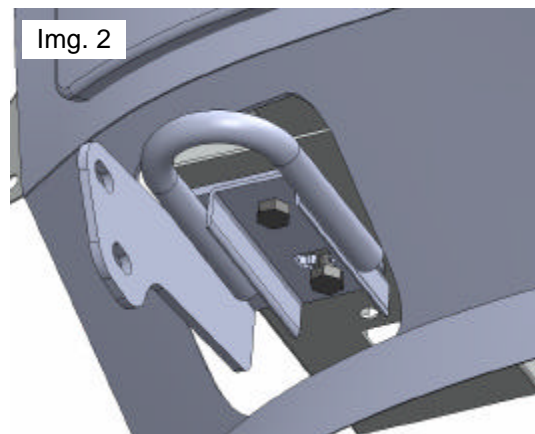

Cleaning and care instructions:

Design:

Quality:

Protect the finish with a non-abrasive automotive wax, (e.g. Pure Carnauba) on a regular basis. The use of any soap, polish, or wax that contains an abrasive is detrimental to the finish, as the compounds scratch the finish and cause

INSTALLATION INSTRUCTIONS

4. If the vehicle **does not have** tow hooks, use the template, printed below, as a guide to modify the lower valance. **NOTE:** Before proceeding with the valance modification, make sure that the supplied paper template has the dimensions clearly printed and check them out. **PROFESSIONAL INSTALLATION RECOMMENDED**

5. Align paper path to the edges shown at **image 3**, mark area to cut out and proceed. Repeat for opposite side.

6. Once openings were made, **place tab bolts** into the chassis as shown at **Img. 4**. Use the wire guide to place tab bolts.

7. Place lower bracket to the chassis, fasten using 1/2" flat and lock washers and hex nuts. **Img. 5**

8. Remove the bolt at the top of the factory bumper support bracket.. **Img. 6**

9. Locate at chassis the 1" Ø hole faces exterior then place "T" bolt introducing the steel bar into the chassis. **Img. 6** **Once "T" bolt has been placed put on a vinyl gasket to prevent fall off into the chassis.**

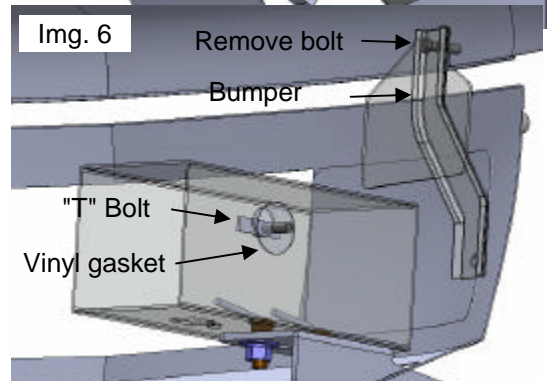
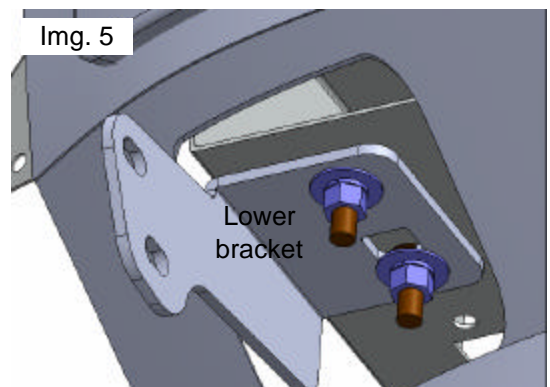
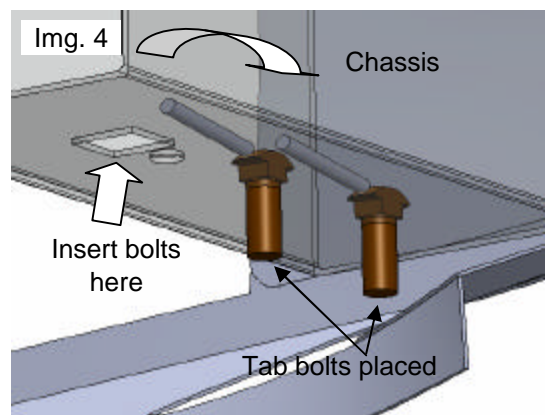
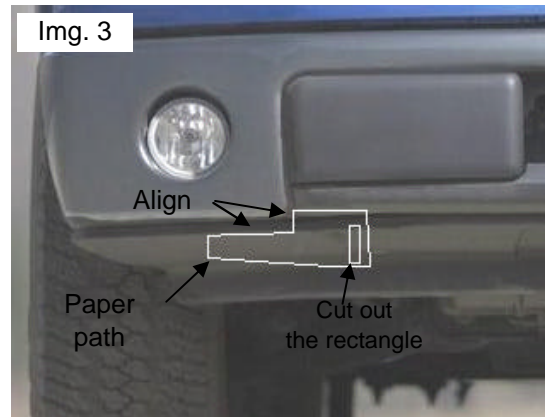

Cleaning and care instructions:

Design:

Quality:

Protect the finish with a non-abrasive automotive wax, (e.g. Pure Carnauba) on a regular basis. The use of any soap, polish, or wax that contains an abrasive is detrimental to the finish, as the compounds scratch the finish and cause corrosion.

INSTALLATION INSTRUCTIONS

10 . **Place auxiliary upper bracket** then fasten the bend end to the bumper support using M8x40 hex head bolt with 1/4" flat washer, secure the other end to the chassis using 3/8" flat and lock washer and hex nut. Leave loose.

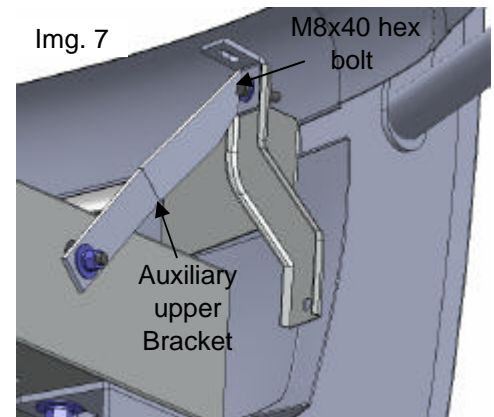

11 . **Insert by front of bumper the upper bracket and fasten to the auxiliary upper bracket** with 3/8 x 1" carriage head bolt, 3/8" flat and lock washer and hex nut. **Img. 8**

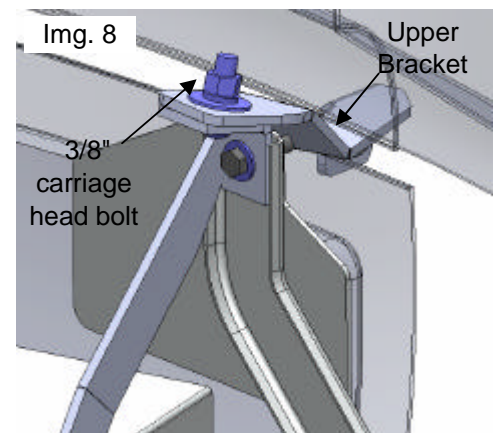

12 . Place Front Guard as **image 9**, to secure lower bracket use 1/2 x 1 1/4" carriage head bolt, 1/2" flat washer and 1/2" lock nut. Secure to upper bracket using 3/8 x 1 1/4" carriage head bolt, 3/8" flat washer and 3/8" lock nut. Leave loose.

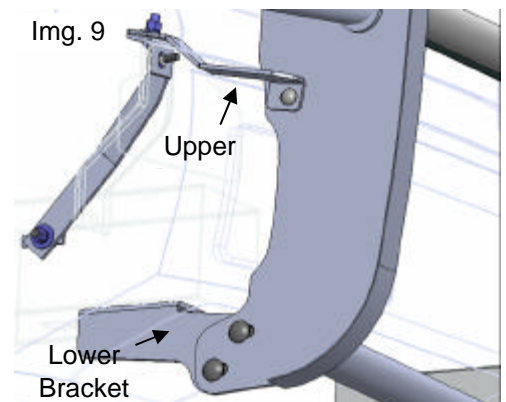

13 . **Only Front modular guard version.** Install the brush guards using a gasket between the side plates and the brush guards. Secure into a place using 3/8 x 1 1/2" button Allen head bolts, and corresponding nuts and washers. Leave hardware loose.

14 . Make any final adjustments to the alignment of the Front Guard and tighten all bolts from bottom to top. **Note: Before tightening the bolts, make sure the upper bracket does not interfere with opening and closing of the hood.**

15 . Do not use abrasive substances or polish to clean your product.

16 . You may need to periodically re-tighten the bolts.

17 . Fill out included warranty card and put in your vehicle.

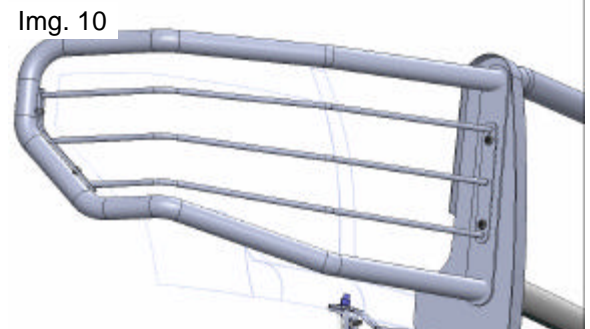

Cleaning and care instructions:

Design:

Quality:

Protect the finish with a non-abrasive automotive wax, (e.g. Pure Carnauba) on a regular basis. The use of any soap, polish, or wax that contains an abrasive is detrimental to the finish, as the compounds scratch the finish and cause corrosion.

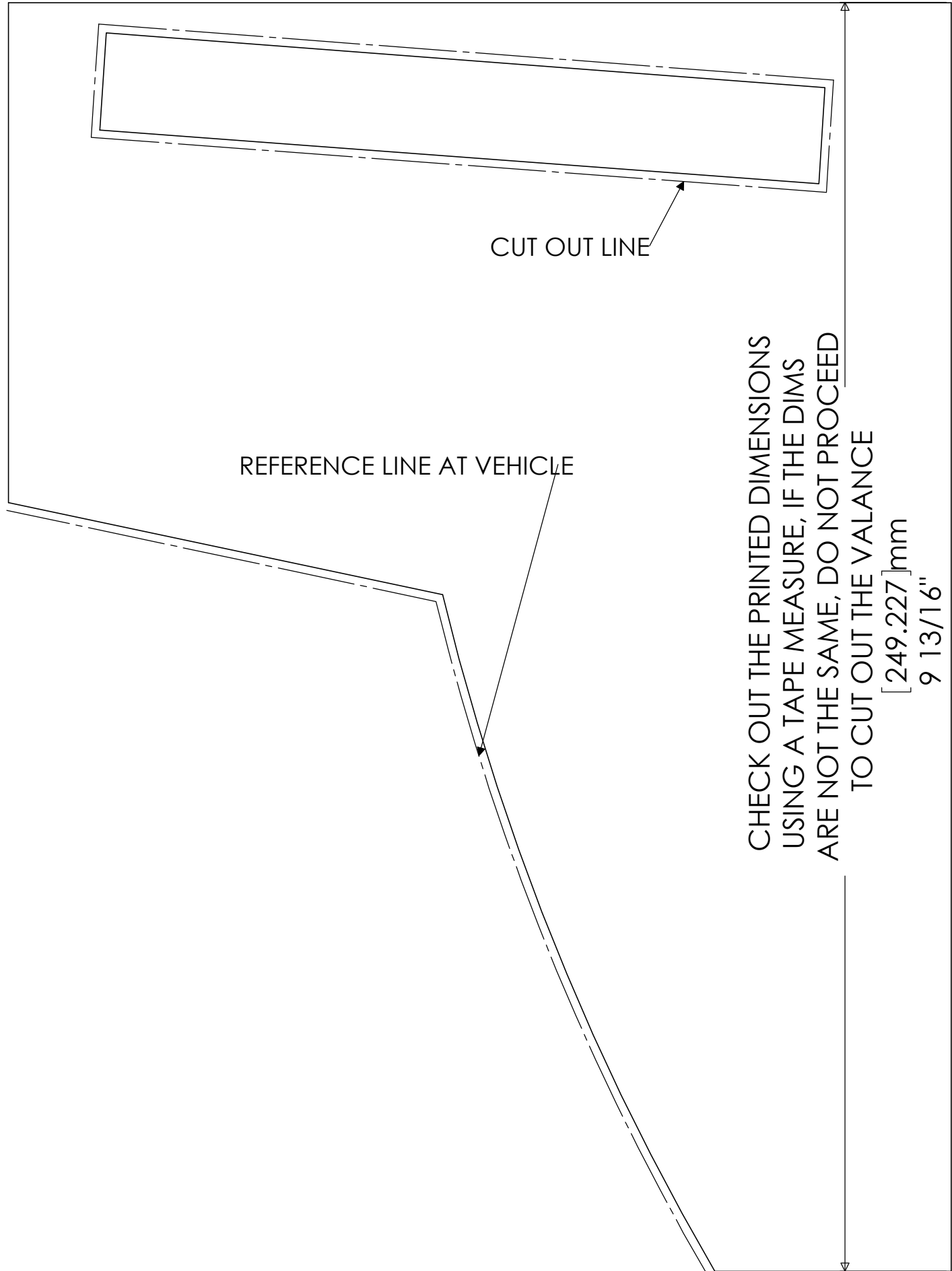

CUT OUT LINE

REFERENCE LINE AT VEHICLE

CHECK OUT THE PRINTED DIMENSIONS
USING A TAPE MEASURE, IF THE DIMS
ARE NOT THE SAME, DO NOT PROCEED
TO CUT OUT THE VALANCE

[249.227]mm
9 13/16"