

INSTALLATION INSTRUCTIONS

DOMINATOR IV

2001 – 2006 Chevrolet Silverado/GMC Sierra Crew Cab 1500, 2500HD, 3500

2011 – 2014 Chevrolet Silverado/GMC Sierra Crew Cab 2500HD, 3500HD (Diesel only)

D44046

Parts List				
Item	QTY	Code	Description	Max Torque
	1 SET	BRK-D44-101	BRACKET	
1	1 set	D44-0460CA	Front Mountina Bracket	
2	1set	D44-0460DA	Middle Mountina Bracket	
3	1 set	D44-0460EA	Rear Mountina Bracket	
4	2 set	391014FA	Front & Middle Auxiliary	
5	1 set	391014EA	Rear Auxiliary Bracket	
6	6	3713312	5/16" Bolt Plate	
7	12		5/16 x 1" Hex Head Bolt B.Z.	11 Lbs Ft
8	18		3/8" Flat Washer B.Z.	
9	12		5/16" Lock Washer B.Z.	
10	6		5/16" Hex Nut	11 Lbs Ft
11	6		5/16" Flat Washer	
12	6		5/16" Lock Washer	
13	6		3/8" 1" Carriacae Head Bolt	
14	6		3/8" Lock Washer	
15	6		3/8" Hex Nut	30 Lbs Ft
16	6		M12 x 120mm Hex Bolt	70 Lbs Ft
17	6		1/2" Lock Washer	
18	6		1/2" Flat Washer	
19	1		Driver Side Step	
20	1		Passenae Side Step	

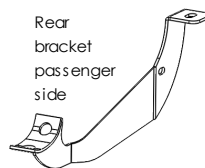
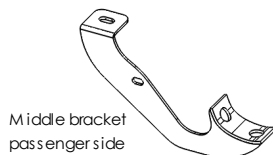
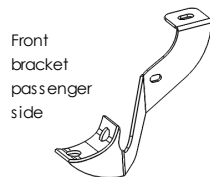

Required Tool:

- A. Ratchet w/5" extension
- B. 9/16", 1/2", 18mm, 19mm, 21mm Socket
- C. 17mm (12 point) Socket
- D. 15mm, 9/16", 1/2" Wrench

The approximate installation time is **45 min.**

Read the installation instructions completely and verify that all of the parts listed are accounted for. If you have defective, missing or damaged parts or need assistance, please contact Go Rhino Products for fast, friendly customer service at: 1-888-427-4466 or email: warranty@gorhino.com

WARNING! GM uses thread-locking compound on all factory body mount bolts. Removal using an air assisted impact or ratchet will damage the body mount bolt threads and the internal nut assembly.

We only recommend using hand tools to slowly remove and reinstall body mount bolts on all GM vehicles.

IMPORTANT! If during the body mount bolt removal process, it becomes increasingly difficult to unscrew the bolt with hand tools, tighten the bolt several rotations to clear the thread-locking compound from the threads, then reverse the direction and continue to unscrew the bolt until it is out. Repeat this process as necessary on all of the body mount bolts. Use of an appropriate anti-seize compound is highly recommended for re-installation. Tighten the body mount bolts to factory torque specifications for your particular model year.

NOTE: The parts kit may include additional fastener that will not be used for this application.

Step-1 Begin the installation by removing the passenger side front body mount bolt. **Picture #1** Keep all existing washers and bushing in place, and attach the front bracket to the vehicle using the factory body mount bolt or one of the supplied 12mm hex bolts depending on the model year of you vehicle. Leave the bolt loose for final adjustment. **Illustration #1.**

NOTE: For model year 2006 and up, use the factory body mounting bolts.

Step-2 Locate the obround hole in the underside of the body and install one of the 5/16" bolt plates. **Picture #1.** Attach the passenger side front auxiliary bracket to the body using the bolt plate, (1) 5/16" flat washer, (1) 5/16" lock washer and (1) 5/16" hex nut. Attach the opposite end of the auxiliary bracket to the side of the front bracket using (1) 3/8" x 1" carriage bolt, (1) 3/8" flat washer, (1) 3/8" lock washer and (1) 3/8" hex nut. Leave the nuts and bolts loose for final adjustment. **Illustration #1.**

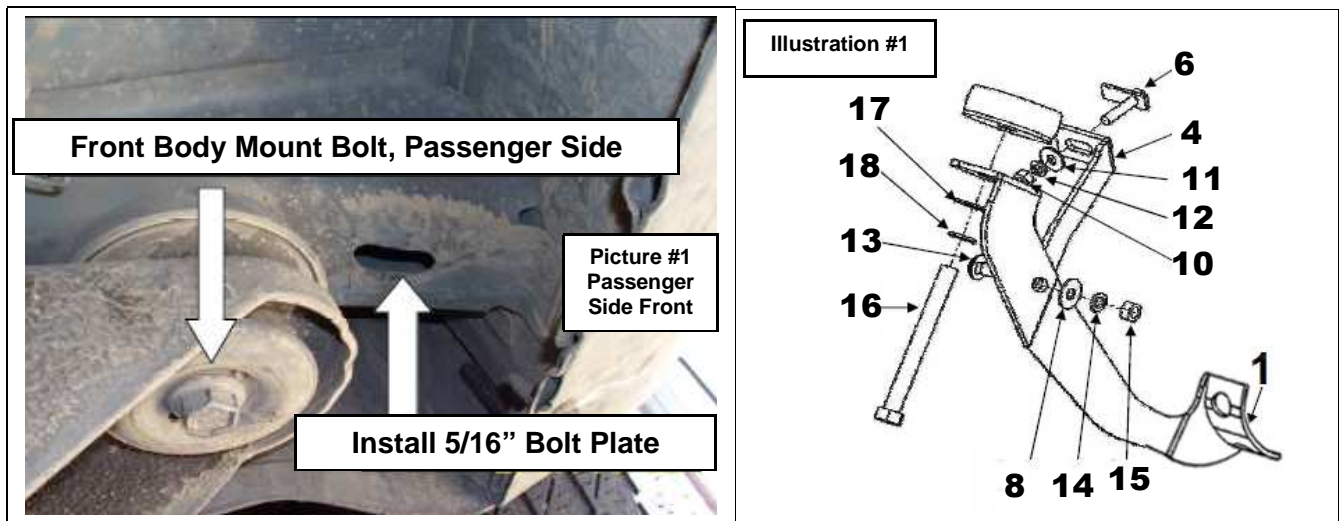

Step-3 Remove the passenger side middle body mount bolt. **Picture #2.** Keep all existing washers and bushing in place, and attach the front bracket to the vehicle using the factory body mount bolt or one of the supplied 12mm hex bolts depending on the model year of you vehicle. Leave the bolt loose for final adjustment. **Illustration #2.**

Step-4 Locate the obround hole in the underside of the body and install one of the 5/16" bolt plates. **Picture #2.** Attach the passenger side middle auxiliary bracket to the body using the bolt plate, (1) 5/16" flat washer, (1) 5/16" lock washer and (1) 5/16" hex nut. Attach the opposite end of the auxiliary bracket to the side of the middle bracket using (1) 3/8" x 1" carriage bolt, (1) 3/8" flat washer, (1) 3/8" lock washer and (1) 3/8" hex nut. Leave the nuts and bolts loose for final adjustment. **Illustration #2.**

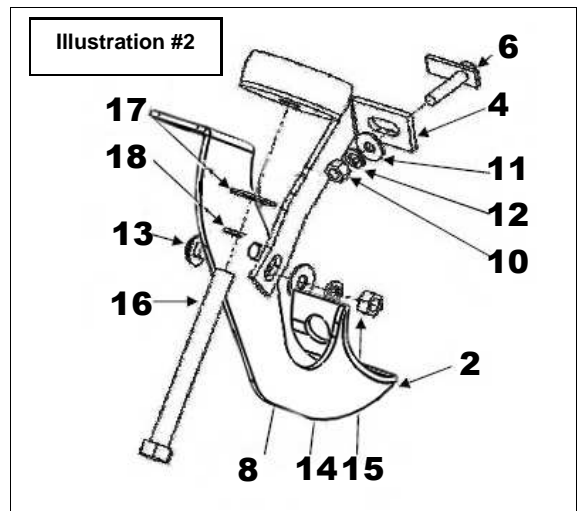
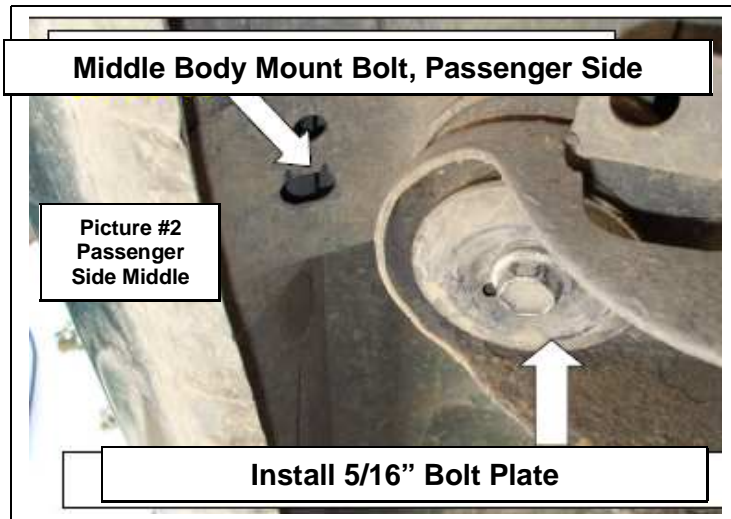

Step-5 Remove the passenger side rear body mount bolt. **Picture #3.** Keep all existing washers and bushing in place, and attach the front bracket to the vehicle using the factory body mount bolt or one of the supplied 12mm hex bolts depending on the model year of you vehicle. Leave the bolt loose for final adjustment. **Illustration #3**

Step-6 Locate and remove the plastic plug in the body rocker panel to expose the round hole, and install one of the 5/16" bolt plates. **Picture #3.** Attach the passenger side rear auxiliary bracket to the body rocker panel using the bolt plate, (1) 5/16" flat washer, (1) 5/16" lock washer and (1) 5/16" hex nut. Attach the opposite end of the auxiliary bracket to the side of the rear bracket using (1) 3/8" x 1" carriage bolt, (1) 3/8" flat washer, (1) 3/8" lock washer and (1) 3/8" hex nut. Leave the nuts and bolts loose for final adjustment. **Illustration #3**

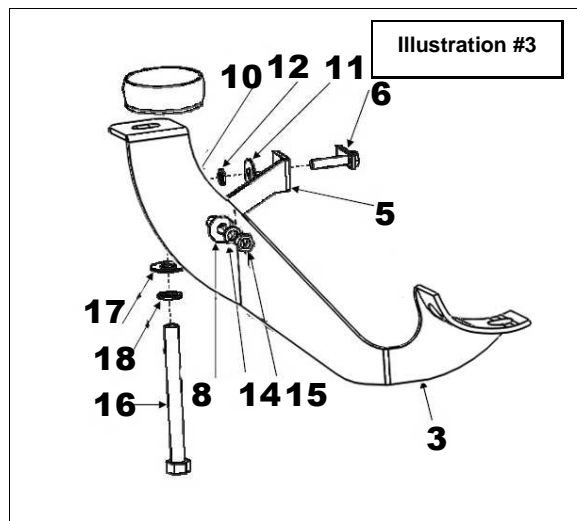
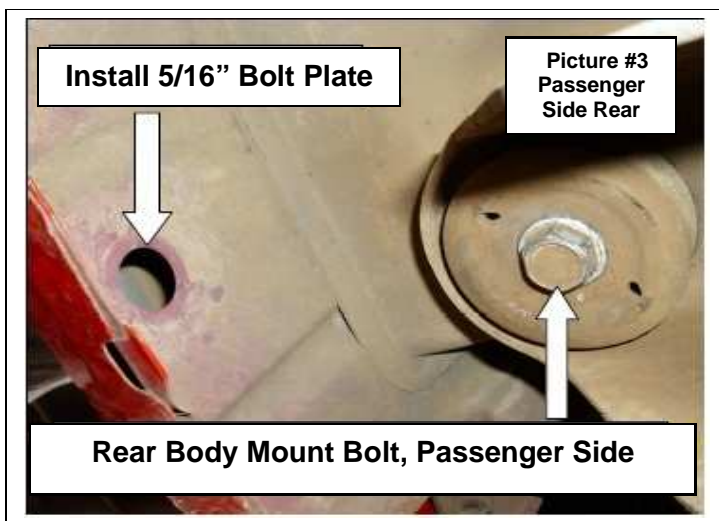

Step-7 Attach the passenger side step to each of the brackets using (2) 5/16" x 1" hex head bolts, (2) 3/8" flat washers B.Z. and (2) 5/16" lock washers B.Z. as shown. **Illustration #4** .

Step-8 Align the side step with the vehicle and tighten all side step and mounting bracket nuts and bolts. Repeat the installation steps to install the driver side brackets and side step. Remember to check and retighten all nuts and bolts periodically.

