

INSTALLATION INSTRUCTIONS

523181BB-523181BBSUZ Dakar / 5523B-5523PS Front Guard 09-10 Suzuki Grand Vitara

Parts List:

No.	Qty.	Description	Torque
1	1 Pc	52318, 5523PS Dakar	-
	1	BRK-52318 Brackets	
2	1 Pc	523180AA Auxiliary bracket	-
3	1 Set	5221841 Lower bracket	-
4	2 Pc	5021812 Nut plate	-
	1	KTE-52318 Hardware Kit	-
5	4 Pc	1/2" Flat washer	-
6	2 Pc	1/2x2" Hex head bolt	50 Lb/Ft
7	2 Pc	5/16" Lock washer	-
8	2 Pc	5/16x1" Hex head bolt	20 Lb/Ft
9	1 Pc	5/16" Flat washer	-
10	4 Pc	3/8" Nut	30 Lb/Ft
11	4 Pc	3/8" Lock washer	-
12	4 Pc	3/8" Flat washer	-
13	2 Pc	1/2x1 1/4" Hex head bolt	50 Lb/Ft
14	2 Pc	3/8" U Bolt	-
15	4 Pc	1/2" Lock washer	-

Tools required:

Ratchet & Screw Driver	1
Socket / Wrench 19mm.	1
Socket / Wrench 14mm.	1
Socket / Wrench 13mm.	1
Socket / Wrench 10mm.	1
Flat screw driver	1

Auxiliary Bracket

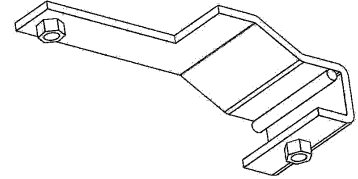

U bolt

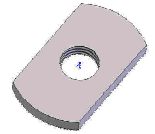

Nut plate

Main Bracket

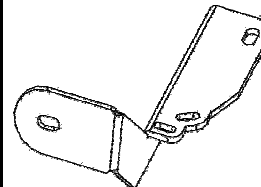

Passenger

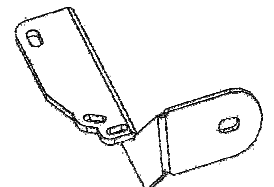

Driver

Aproximated installation: 30min.

Instructions:

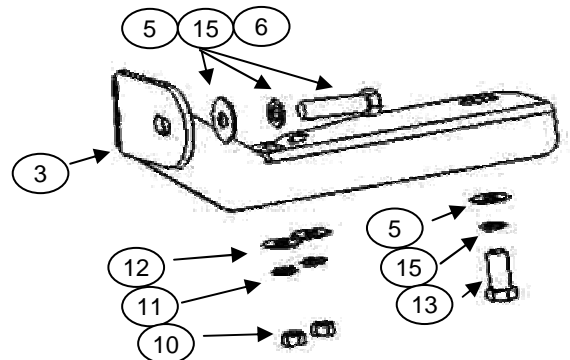
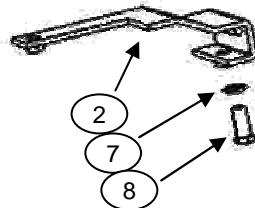
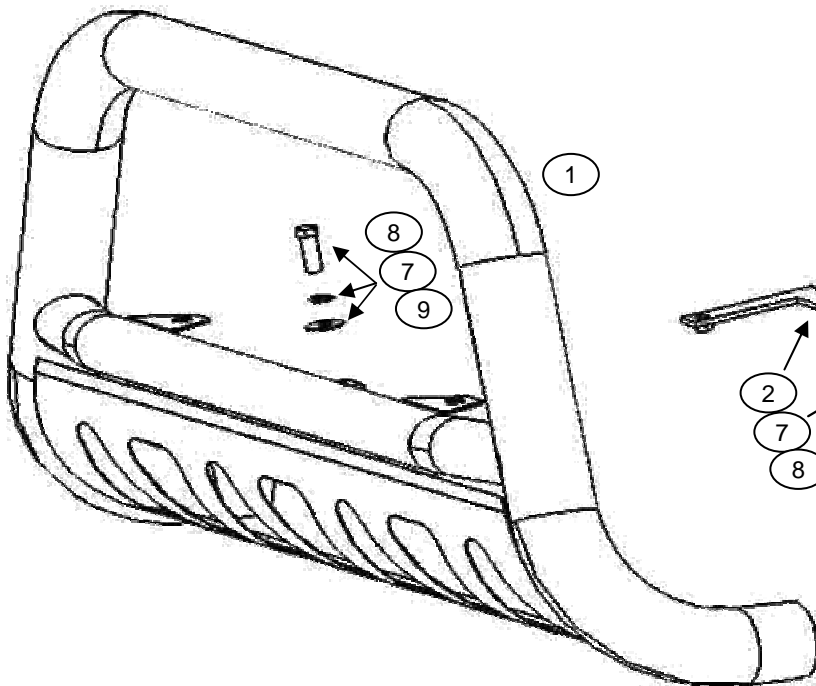

Cleaning and care instructions:

Keep your product clean. Do not use abrasive cleaners or polish. We recommend only non-abrasive automotive wax such as pure

Design:

Quality:

Revised: 31/03/10

INSTALLATION INSTRUCTIONS

523181BB-523181BBSUZ Dakar / 5523B-5523PS Front Guard 09-10 Suzuki Grand Vitara

1. Before beginning the installation, please read all directions carefully and verify that all necessary hardware is accounted for. If any parts are missing, stop the installation and contact your distributor immediately.

2. Identify the installation locations shown in image 2.

3. Remove the front plastic shield underneath the vehicle, pull out the plastic rivets using a flat screwdriver and the factory bolts with a 10mm socket.

4. Refer to the image 1 and 3 as installation guide.

Img. 2



Img. 3

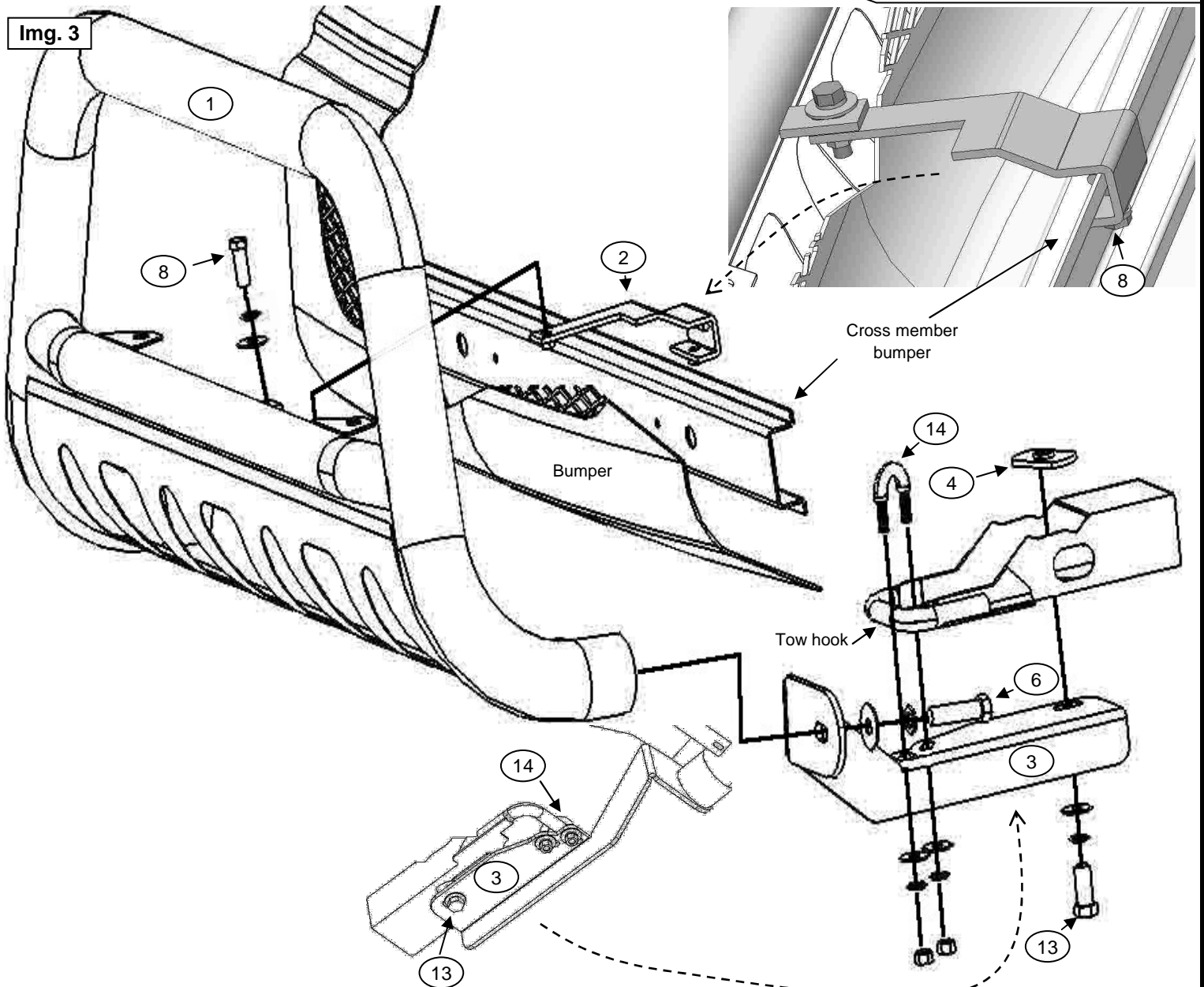

Cleaning and care instructions:

Keep your product clean. Do not use abrasive cleaners or polish. We recommend only non-abrasive automotive wax such as pure

Design:

Quality:

Revised: 31/03/10