

INSTALLATION INSTRUCTIONS

4052 Sidebar

92 – 99 Chevy Suburban, Yukon XL

Parts List:**QTY**

P01 (1) Sidebar set
(Driver & Passenger)
P02 (2) Front mounting bracket
P03 (2) Rear mounting bracket
P04 (2) Front auxiliary mounting bracket
P05 (2) Rear auxiliary mounting bracket

(1) Hardware kit including:

T01 (2) 1/2 x 2" Flat head bolt
T02 (2) 1/2 x 1 1/2" Hex head bolt
T03 (2) 1/2 x 1 1/4" cut head bolt
T04 (2) M12 x 120 mm Hex head bolt
T05 (6) 1/2" Flat washer
T06 (2) 1/2" Lock washer
T07 (2) 1/2" Hex nut

Tools required:

3/4" Socket Ratchet
3/4" Wrench 18mm Socket

Instructions:**Aproximated installation time: 30 min.**

1. Read and understand instructions completely before beginning installation.
2. Sidebar set consist of a driver and passenger side. Be sure to determinate the correct side before installation.
3. Remove the front body mounting bolts from mounts located under the cab of the vehicle. Place the front mounting bracket up to the body mounts and bolt using the factory bolts. Note: If the vehicle is 4x4 replace the factory mounting bolts for M12 x 120 mm hex head bolts provided.
4. To install rear mounting bracket. Bolt rear mounting bracket to the sidebar using 1/2 x 2" flat head bolt, place the rear auxiliary mounting bracket between the sidebar and the rear mounting bracket. If the vehicle is 4x2 place the flat bolt in the middle hole, if is 4x4 place in the lower hole. Then introduce a 1/2 x 1 1/4" cut head bolt into the o-bround hole, turn 1/4 the bolt to secure into the hole. Bolt to the rear mounting bracket using flat washer and 1/2" hex nut. Note: On the left outboard side of frame, just behind the spring hanger bracket and below the o-bround hole is a plastic clamp base that retains a wiring harness. This clamp mounting base sticks thru the side of the frame and must be trimmed off flush with the side of the frame for this installation.
5. Place the sidebar up to the front mounting brackets. Bolt using the 1/2 x 1 1/2" hex head bolt, flat and lock washer. Leave loose.
6. Make any final adjustments to the alignment of the sidebar and tighten all bolts. Repeat for the opposite side.
7. You may need to periodically re-tighten the bolts.

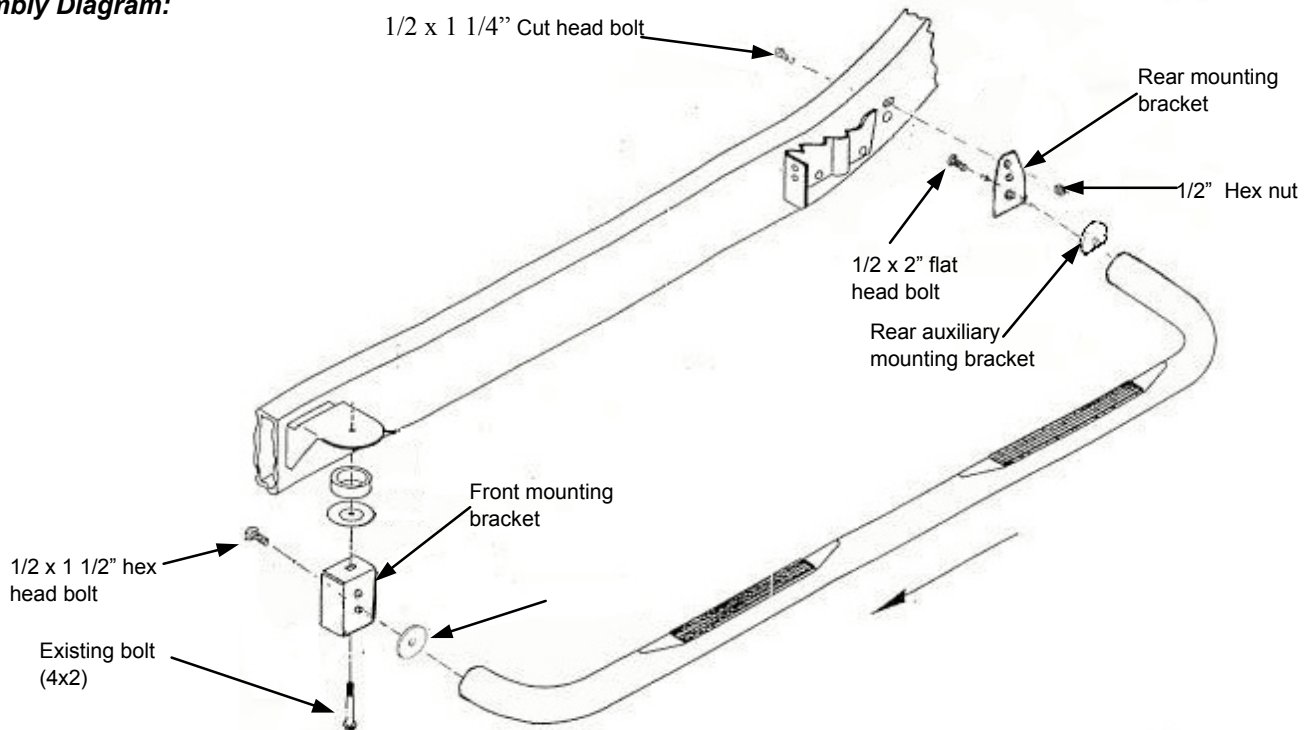
Assembly Diagram:**Cleaning and care instructions:****Diseño:****Calidad:**

Protect the finish with a non-abrasive automotive wax, (e.g. Pure Carnauba) on a regular basis. The use of any soap, polish, or wax that contains an abrasive is detrimental to the finish, as the compounds scratch the finish and cause corrosion.