

SUMATRATM Series 3000

Chrome Modular StepGuard

1999-UP TOYOTA 4 RUNNER 2/4WD PART # 3723MC

PARTS LIST

| | | | |
|---|-----------------------------|----|------------------------------------|
| 2 | 1/4" SOCKET SCREWS | 10 | 3/8" LOCK WASHERS |
| 2 | 5/16" X 1" HEX BOLTS | 6 | 3/8" FLAT WASHERS |
| 2 | 5/16" LOCK WASHERS | 10 | 3/8" HEX NUTS |
| 4 | 5/16" FLAT WASHERS | 2 | NYLON FLANGE WASHERS |
| 2 | 5/16" HEX NUTS | 2 | 1487T TOP BRACKETS |
| 8 | 3/8" X 1" HEX BOLTS | 1 | 1487P PASSENGER SIDE FRAME BRACKET |
| 6 | 3/8" X 1" BUTTON HEAD BOLTS | 1 | 1487D DRIVER SIDE FRAME BRACKET |

ASSEMBLY INSTRUCTIONS

- STEP 1:** ASSEMBLE GRILLE AND BRUSH GUARD ASSEMBLY AS FOLLOWS PER DIAGRAM.
- STEP 2:** PLACE CENTER GUARD SIDE PLATES ON A FLAT SURFACE FACE DOWN.
- STEP 3:** ATTACH BOTTOM STEP TUBE TO INSIDE OF GRILLE GUARD SIDE PLATES USING 3/8" X 1" BUTTON HEAD BOLTS. DO NOT SECURE.
- STEP 4:** ASSEMBLE BRUSH GUARDS LEFT AND RIGHT BY SLIDING THROUGH SIDE PLATES, FLANGED WASHERS THEN INTO TOP TUBE. NOTE: LUBRICATE BRUSH GUARD TUBES TO EASE ASSEMBLY.
- STEP 5:** ATTACH EURO TUBE TO BRUSH GUARDS USING 5/16" X 1 3/4" FLAT HEAD SCREWS AS SHOWN IN DIAGRAM INCLUDED WITH EURO TUBE. DO NOT SECURE.
- STEP 6:** POSITION CENTER PLATE BETWEEN SIDE PLATES, ATTACH CENTER PLATE TO SIDE PLATES AND BRUSH GUARDS USING 3/8" X 1" HEX BOLTS, LOCK WASHERS AND HEX NUTS. NOTE: THREADS MUST FACE OUTWARDS ON BOLTS.
- STEP 7:** ATTACH HEAD LIGHT PROTECTORS FIRST TO BRUSH GUARDS WITH 1/4" X 3/4" BUTTON HEAD BOLTS THEN TO GRILLE GUARD USING 5/16" X 1" BUTTON HEAD BOLTS AND LOCK NUTS.
- STEP 8:** ALIGN GRILLE AND BRUSH GUARD ASSEMBLY AND SECURE ALL NUTS AND BOLTS.
- STEP 9:** ROTATE TOP TUBE TOWARDS GRILLE AND SECURE USING 1/4" SOCKET SCREWS.

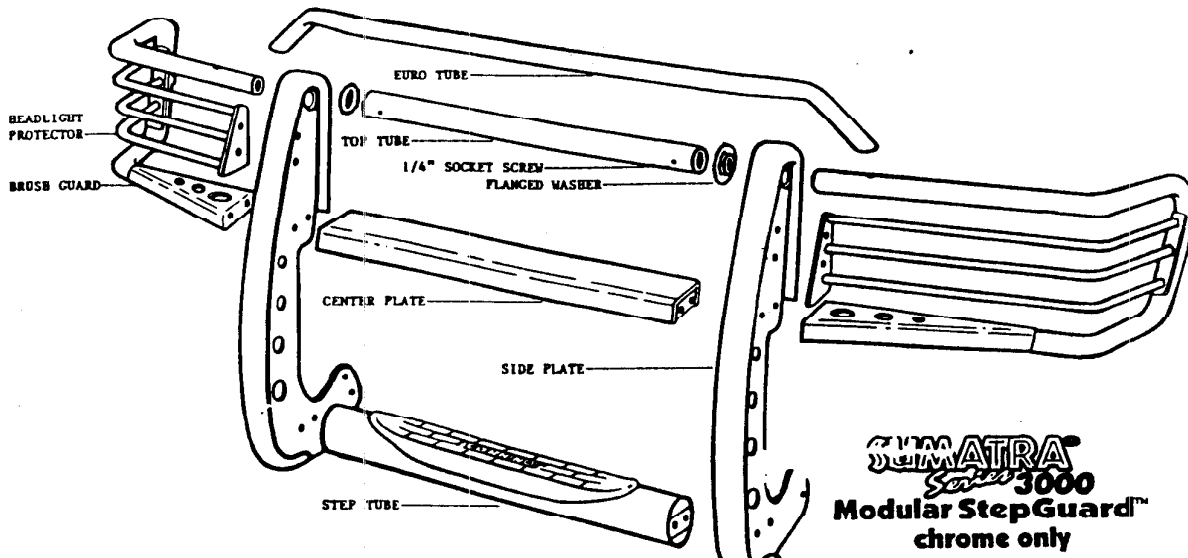

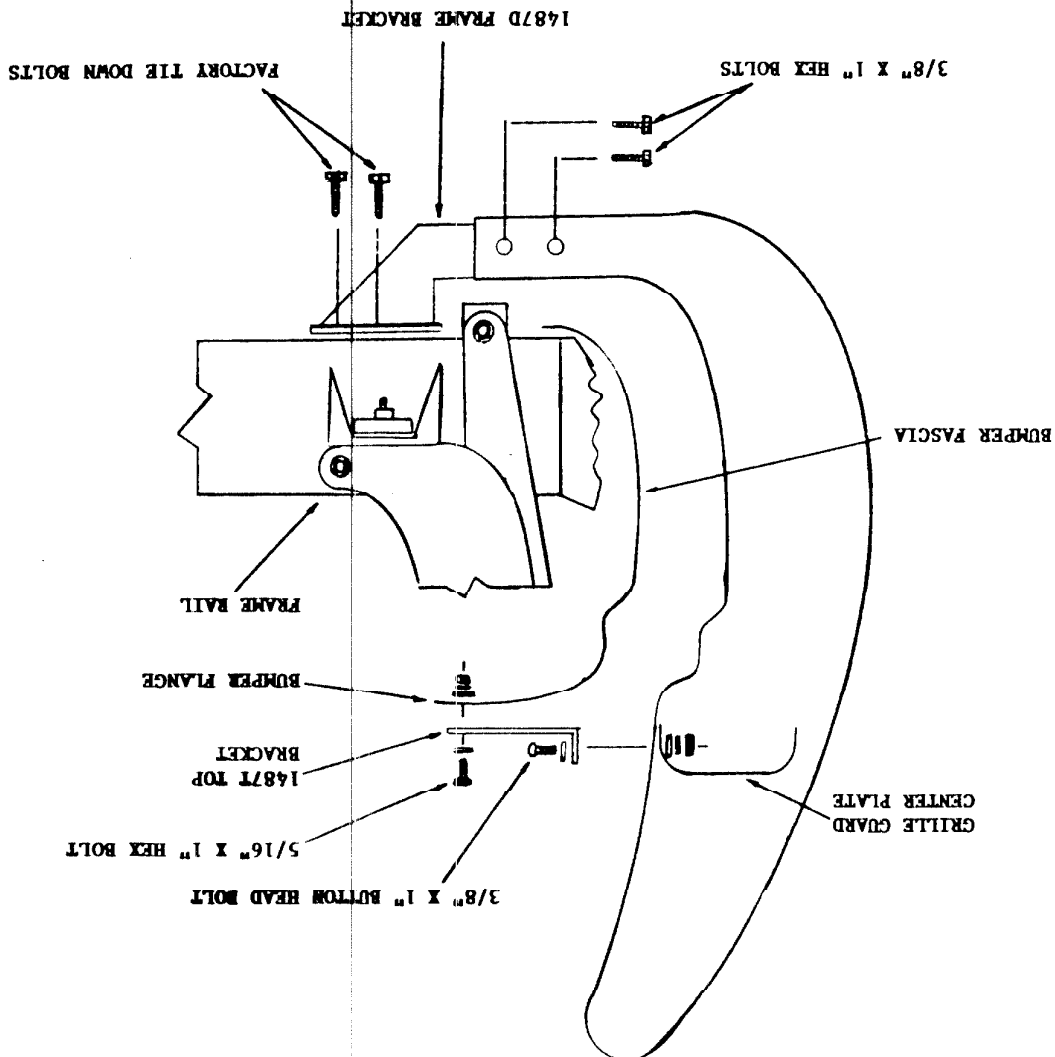

- STEP 1: REMOVE TIE DOWN FROM BOTTOM OF DRIVER SIDE FRAME RAIL.
- STEP 2: USING BOLTS FROM TIE DOWN ATTACH, 1487D DRIVER SIDE FRAME BRACKET TO BOTTOM OF FRAME AS SHOWN IN DIAGRAM. DO NOT TIGHTEN.
- STEP 3: REMOVE TOW HOOK AND TIE DOWN FROM BOTTOM OF PASSENGER SIDE FRAME RAIL.
- STEP 4: USING BOLTS ALONG WITH TOW HOOK REMOVED IN STEP #3, ATTACH 1487D PASSENGER SIDE FRAME BRACKET TO BOTTOM OF FRAME. DO NOT TIGHTEN.
- STEP 5: OPEN HOOD AND REMOVE GRILLE FROM FRONT OF VEHICLE TO EXPOSE PLASTIC TRIM RIVETS ALONG BUMPER FLANGE.
- STEP 6: LOCATE AND REMOVE THE TWO RIVETS THAT MEASURE APPROXIMATELY 2 3/4" APART.
- STEP 7: ATTACH 1487D TOP BRACKETS TO BUMPER FLANGE USING 5/16" X 1" HEX BOLTS, FLAT WASHERS, LOCK WASHERS AND HEX NUTS. DO NOT TIGHTEN.
- STEP 8: ATTACH THE GRILLE AND BRUSH GUARD ASSEMBLY TO THE OUTSIDE OF THE FRAME BRACKETS USING 3/8 X 1" HEX BOLTS, FLAT WASHERS, LOCK WASHERS AND HEX NUTS. AND THE CENTER PLATE TO TOP BRACKETS USING 3/8" X 1" BOTTOM HEAD BOLTS, FLAT WASHERS, LOCK WASHERS AND HEX NUTS. DO NOT TIGHTEN.
- STEP 9: ALIGN GRILLE AND BRUSH GUARD ASSEMBLY WITH FRONT OF VEHICLE AND TIGHTEN ALL NUTS AND BOLTS.
- STEP 10: REATTACH GRILLE TO FRONT OF VEHICLE.

INSTALLATION INSTRUCTIONS