

2000 TOYOTA TUNDRA PICKUP 2/4WD CHROME STEP GUARD PART NO. 3708MC

(PARTS LIST)

2	1/4" SOCKET SCREWS
2	NYLON FLANGED WASHERS
4	5/16" X 1" HEX BOLTS
4	5/16" LOCK WASHERS
6	5/16" FLAT WASHERS
4	5/16" HEX NUTS
4	3/8" X 1" HEX BOLTS
4	3/8" X 1" BUTTON HEAD BOLTS
4	3/8" LOCK WASHERS
4	3/8" HEX NUTS
4	1/2" X 1 1/2" HEX BOLTS
4	1/2" FLAT WASHERS
4	1/2" LOCK WASHERS
4	1/2" HEX NUTS
1	1481AD DRIVER SIDE UPPER BRACKET
1	1481AP PASSENGER SIDE UPPER BRACKET
1	1481BD DRIVER SIDE FRAME BRACKET
1	1481BP PASSENGER SIDE FRAME BRACKET

(ASSEMBLY INSTRUCTIONS)

- STEP 1. ASSEMBLE GRILLE AND BRUSH GUARD ASSEMBLY AS FOLLOWS PER DIAGRAM.
- STEP 2. PLACE CENTER GUARD SIDE PLATES ON A FLAT SURFACE FACE DOWN.
- STEP 3. ATTACH BOTTOM STEP TUBE TO INSIDE OF GRILLE GUARD SIDE PLATES USING 3/8" X 1" BUTTON HEAD BOLTS. DO NOT SECURE.
- STEP 4. ASSEMBLE BRUSH GUARDS LEFT AND RIGHT BY SLIDING THROUGH SIDE PLATES, FLANGED WASHERS THEN INTO TOP TUBE. NOTE: LUBRICATE BRUSH GUARD TUBES TO EASE ASSEMBLY.
- STEP 5. ATTACH EURO TUBE TO BRUSH GUARDS USING 5/16" X 1 3/4" FLAT HEAD SCREWS AS SHOWN IN DIAGRAM INCLUDED WITH EURO TUBE. DO NOT SECURE.
- STEP 6. POSITION CENTER PLATE BETWEEN SIDE PLATES, ATTACH CENTER PLATE TO SIDE PLATES AND BRUSH GUARDS USING 3/8" X 1" HEX BOLTS, LOCK WASHERS AND HEX NUTS. NOTE: THREADS MUST FACE OUTWARDS ON BOLTS.
- STEP 7. ATTACH HEAD LIGHT PROTECTORS FIRST TO BRUSH GUARDS WITH 1/4" X 3/4" BUTTON HEAD BOLTS THEN TO GRILLE GUARD USING 5/16" X 1" BUTTON HEAD BOLTS AND LOCK NUTS.
- STEP 8. ALIGN GRILLE AND BRUSH GUARD ASSEMBLY AND SECURE ALL NUTS AND BOLTS.
- STEP 9. ROTATE TOP TUBE TOWARDS GRILLE AND SECURE USING 1/4" SOCKET SCREWS.

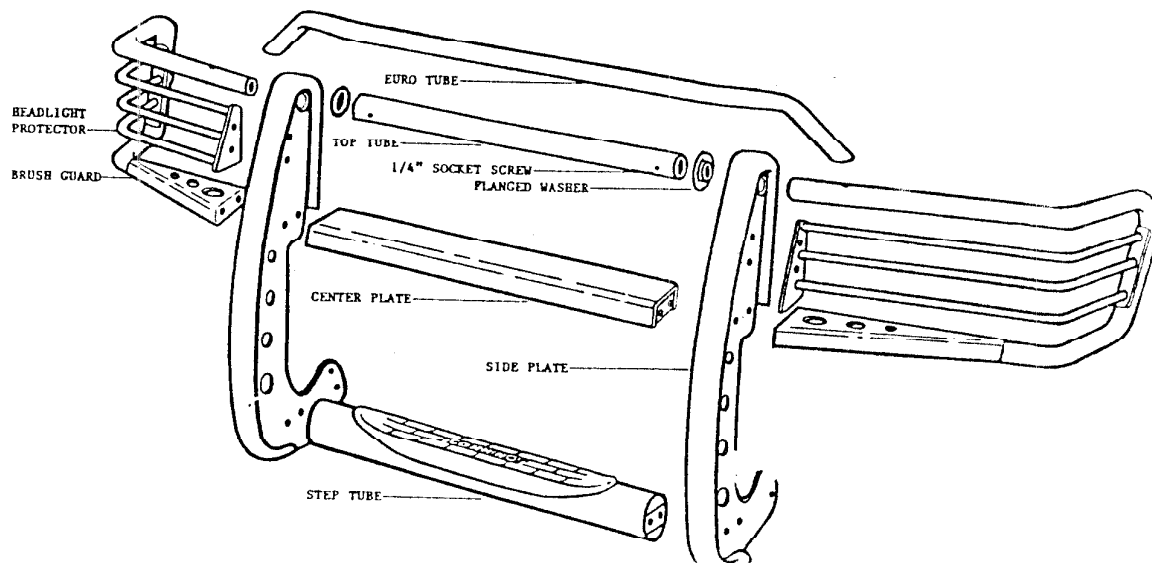

(INSTALLATION INSTRUCTIONS)

- STEP 1. REMOVE TIE DOWN FROM BOTTOM OF DRIVER SIDE FRAME RAIL.
- STEP 2. USING BOLTS FROM TIE DOWN, ATTACH 1481BD DRIVER SIDE FRAME BRACKET TO BOTTOM OF FRAME AS SHOWN IN DIAGRAM. DO NOT TIGHTEN.
- STEP 3. REPEAT THE ABOVE FOR 1481BP PASSENGER SIDE FRAME BRACKET.
- STEP 4. OPEN THE HOOD AND LOCATE THE PLASTIC RIVETS SECURING THE BUMPER TRIM TO TOP OF BUMPER.
- STEP 5. REMOVE THE THE TWO RIVETS THAT MEASURE APPROXIMATELY 31 3/8" APART.
- STEP 6. ATTACH 1481AD AND 1481AP UPPER BRACKETS TO HOLES IN BUMPER USING 5/16" X 1" HEX BOLTS, FLAT WASHERS, LOCK WASHERS AND HEX NUTS. DO NOT TIGHTEN.
- STEP 7. ATTACH THE GRILLE AND BRUSH GUARD ASSEMBLY TO THE OUTSIDE OF THE FRAME BRACKETS USING 1/2" X 1 1/2" HEX BOLTS AND TO THE UPPER BRACKETS USING 5/16" X 1" HEX BOLTS, FLAT WASHERS, LOCK WASHERS AND HEX NUTS AS SHOWN.
- STEP 8. ALIGN THE GRILLE AND BRUSH GUARD ASSEMBLY WITH FRONT OF VEHICLE AND TIGHTEN ALL NUTS AND BOLTS.

