

3000 SERIES STEPGUARD

GRILLE GUARD ASSEMBLY INSTRUCTIONS

PART NO. 3616 B&C 99-03 JEEP GRAND CHEROKEE 2/4 WD (WILL FIT LAREDO)

Do not attempt to install this product on any vehicle other than the one it is designed for and listed above!

PART LIST

<u>QTY</u>	<u>PART DESCRIPTION</u>	<u>QTY</u>	<u>PART DESCRIPTION</u>
4	1/2 x 1 1/2" HEX BOLT	8	3/8" HEX NUT
4	1/2 x 2 1/2" HEX BOLT	2	3/8" "U" NUT
4	1/2" LOCK WASHER	2	1/4 x 3/4" BUTTON HEAD BOLT
4	1/2" HEX NUT	2	1247A BOLT TABS
4	3/8 x 1" HEX BOLT	2	1247B BOLT TABS
4	3/8 x 1" BUTTON HEAD BOLT	2	1247T TOP BRACKETS
2	3/8 x 1 1/4" HEX BOLT	1	1247D DRIVER SIDE FRAME BRKT
6	3/8" FLAT WASHER	1	1247P PASSENGER SIDE FRAME BRKT
4	3/8" LOCK WASHER	1	P200 PLUG KIT

ASSEMBLY INSTRUCTIONS

READ THE ASSEMBLY AND INSTALLATION INSTRUCTIONS COMPLETELY BEFORE YOU BEGIN.

STEP 1. BEGIN THE GRILLE ASSEMBLY BY LAYING THE COMPONENTS OUT ON A PROTECTIVE SURFACE.

STEP 2. INSTALL THE TUBE CONNECTORS FROM THE P200 PLUG KIT INTO THE TOP TUBE.

STEP 3. POSITION THE STEP TUBE, CENTER PLATE AND TOP TUBE BETWEEN THE GRILLE GUARD SIDE PLATES.

STEP 4. ATTACH THE STEP TUBE TO THE SIDE PLATES USING THE 3/8" x 1" BUTTON BOLTS, THE CENTER PLATE USING THE 3/8" X 1" HEX HEAD BOLTS, LOCK WASHERS AND NUTS, AND TOP TUBE USING THE P200 PLUG KIT HARDWARE.

STEP 5. ALIGN THE GRILLE ASSEMBLY AND TIGHTEN ALL NUTS AND BOLTS.

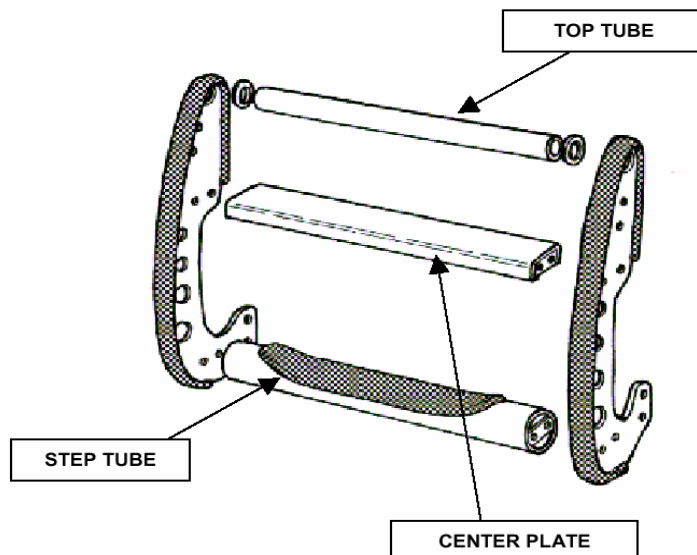

INSTALLATION INSTRUCTIONS

STEP 1. BEGIN INSTALLATION BY LOOKING UNDER THE VEHICLE BUMPER AND LOCATING THE THREE PLASTIC RIVETS ALONG THE BOTTOM EDGE OF THE BUMPER FASCIA. USE A SLOTTED HEAD SCREW DRIVER TO PRY THE CENTER PINS OUT THEN PULL DOWN ON FASCIA TO FREE THE RIVET CLIPS. **NOTE:** SAVE THE RIVET PINS AND CLIPS.

STEP 2. IF EQUIPPED WITH FACTORY TOW HOOKS, REMOVE THE BOOKS AND BRACKETS FROM BOTTOM OF FRAME. **NOTE:** LEAVE EXISTING "U" NUTS IN PLACE.

STEP 3. FOR LOWER FRAME BRACKETS, START AND COMPLETE ONE SIDE BEFORE MOVING ON TO THE OTHER SIDE. PULL DOWN ON BUMPER FASCIA AND INSERT 1247D DRIVER SIDE FRAME BRACKET FROM BEHIND BUMPER FASCIA AND OUT THROUGH OPENING IN BUMPER FASCIA. THE FRONT OF THE BRACKETS HAS TWO 1/2" HOLES WHICH THE GRILLE GUARD WILL MOUNT TO. **NOTE:** PULLING HARDER ON BUMPER FASCIA WILL ALLOW INSERTING BRACKET EASIER.

STEP 4. ALIGN THE THREE HOLES IN BRACKET WITH EXISTING HOLES IN VEHICLE FRAME. IF "U" NUT EXISTS, INSERT BOLT FROM TOW HOOK BRACKET TO HOLD BRACKET IN PLACE. IF NO "U" NUT EXISTS, INSTALL "U" NUT AND SECURE USING 3/8" BOLT SUPPLIED. **NOTE:** HAND TIGHTEN ONLY.

STEP 5. PULL DOWN ON BUMPER FASCIA AND INSERT ONE OF THE 1247B BOLT TABS FROM OPENING IN BUMPER FASCIA AND INTO OVAL OPENING IN METAL BUMPER CHANNEL. SLIDE THE BOLT THROUGH EXISTING FRAME HOLE AND BRACKET. SECURE USING 3/8" HEX NUT AND WASHER SUPPLIED. **NOTE:** HAND TIGHTEN ONLY.

STEP 6. INSERTION OF 1247A BOLT TAB MAY BE VIEWED EASIER FROM UNDERNEATH VEHICLE. LOCATE THE SQUARE OPENING DIRECTLY BEHIND HOLE IN REAR OF BRACKET AND INSERT 1247A BOLT TAB. SLIDE THE BOLT THROUGH EXISTING FRAME HOLE AND BRACKET, SECURE USING 3/8" HEX NUT AND WASHER SUPPLIED. **NOTE:** TAB MAY HAVE TO BENT SLIGHTLY TO SLIDE INTO PLACE.

STEP 7. REPEAT THE ABOVE FOR THE PASSENGER SIDE.

STEP 8. ATTACH THE GRILLE GUARD ASSEMBLY TO THE OUTSIDE OF THE FRAME BRACKETS USING 1/2 x 1 1/2" HEX BOLTS, LOCK WASHERS AND HEX NUTS. DO NOT TIGHTEN. **NOTE:** FOR TOW HOOKS, ATTACH HOOKS TO LOWER HOLES IN GRILLE GUARD USING 1/2 x 2 1/2" HEX BOLTS.

STEP 9. OPEN THE HOOD, LOCATE AND REMOVE THE TWO TORX HEAD BOLTS FROM TOP OF HOOD OPENING. **NOTE:** THE BOLTS ARE APPROXIMATELY 21 1/8" APART. ATTACH 1247T TOP BRACKETS TO HOOD OPENING USING THE TORX BOLTS AND TO THE BOTTOM OF THE GRILLE GUARD TOP TUBE USING THE 1/4 x 3/4" BUTTON HEAD BOLTS SUPPLIED.

STEP 10. ALIGN THE GRILLE GUARD ASSEMBLY WITH FRONT OF VEHICLE AND TIGHTEN ALL NUTS AND BOLTS.

