

**3000 SERIES STEPGUARD**  
GRILLE GUARD ASSEMBLY INSTRUCTIONS  
PART NO. 3378MB & 3378MC 01-05 FORD RANGER 2/4WD  
**Do not attempt to install this product on any vehicle other than the one it is designed for and listed above!**

**PART LIST**

<b><u>QTY</u></b>	<b><u>PART DESCRIPTION</u></b>	<b><u>QTY</u></b>	<b><u>PART DESCRIPTION</u></b>
4	3/8 x 1" BUTTON BOLT	2	1151A TOP BRACKETS
10	3/8 x 1" HEX BOLT	1	1151D DRIVER SIDE FRAME BRACKET
8	3/8" FLAT WASHER	1	1151P PASSENGER SIDE FRAME BRKT
12	3/8" LOCK WASHER	1	P200 PLUG KIT
12	3/8" HEX NUT	2	1/2" HOLE 1/4 THICK X 2" O.D. WASHER
2	1/2 x 4 1/2" HEX BOLT	2	3/8 x 1 3/4" T-BOLT
2	1/2" FLAT WASHER		
2	1/2" LOCK WASHER		
2	1/2" HEX NUT		

**ASSEMBLY INSTRUCTIONS**

**READ THE ASSEMBLY AND INSTALLATION INSTRUCTIONS COMPLETELY BEFORE YOU BEGIN.**

**STEP 1.** BEGIN THE GRILLE ASSEMBLY BY LAYING THE COMPONENTS OUT ON A PROTECTIVE SURFACE.

**STEP 2.** INSTALL THE TUBE CONNECTORS FROM THE P200 PLUG KIT INTO THE TOP TUBE.

**STEP 3.** LOOSELY ATTACHING THE BOTTOM PLATE TO THE GRILLE GUARD SIDE PLATES USING THE 3/8" X 1" BUTTON BOLTS.

**STEP 4.** POSITION THE CENTER PLATE BETWEEN THE SIDE PLATES, AND ATTACH THE CENTER PLATE USING THE 3/8" X 1" HEX HEAD BOLTS, LOCK WASHERS, AND NUTS.

**STEP 5.** ALIGN THE GRILLE ASSEMBLY AND TIGHTEN ALL NUTS AND BOLTS. NOTE: SECURE THE TOP TUBE USING THE P200 PLUG KIT HARDWARE.

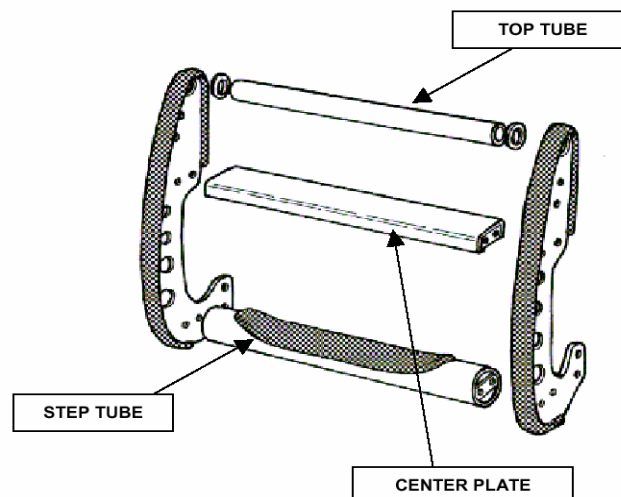

## INSTALLATION INSTRUCTIONS

**NOTE:** IF EQUIPPED, REMOVE THE ATTACHMENT SCREWS AND PLASTIC AIR DUCT FROM THE BOTTOM OF THE FRAME. THIS WILL MAKE ACCESS TO THE UPPER BUMPER BOLTS EASIER.

**STEP 1.** BEGIN THE INSTALLATION BY LOCATING AND REMOVING THE PASSENGER SIDE 10MM UPPER BUMPER BOLT THAT CONNECTS THE BUMPER TO THE BUMPER SUPPORT BRACKET. LOOSELY ATTACH ONE OF THE 1151A UPPER BRACKETS TO THE BUMPER SUPPORT BRACKET USING THE FACTORY BOLT AS SHOWN IN DIAGRAM "A".

**STEP 2.** LOOSELY ATTACH 1151P BRACKET TO THE BOTTOM OF THE FRAME USING THE 3/8" T-BOLT, AND TO THE SIDE USING THE 1/2 x 4 1/2" HEX BOLT, WASHERS AND NUTS AS SHOW IN DIAGRAM "B".

**STEP 3.** REPEAT THE ABOVE STEPS FOR THE DRIVER SIDE BRACKETS.

**STEP 4.** ATTACH THE GRILLE AND BRUSH GUARD ASSEMBLY TO THE MOUNTING BRACKETS, USING 3/8 x 1" BOLTS, WASHERS, AND NUTS. ALIGN THE GRILLE GUARD ASSEMBLY WITH THE FRONT OF VEHICLE AND TIGHTEN ALL NUTS AND BOLTS. RE-ATTACH AIR DUCT.

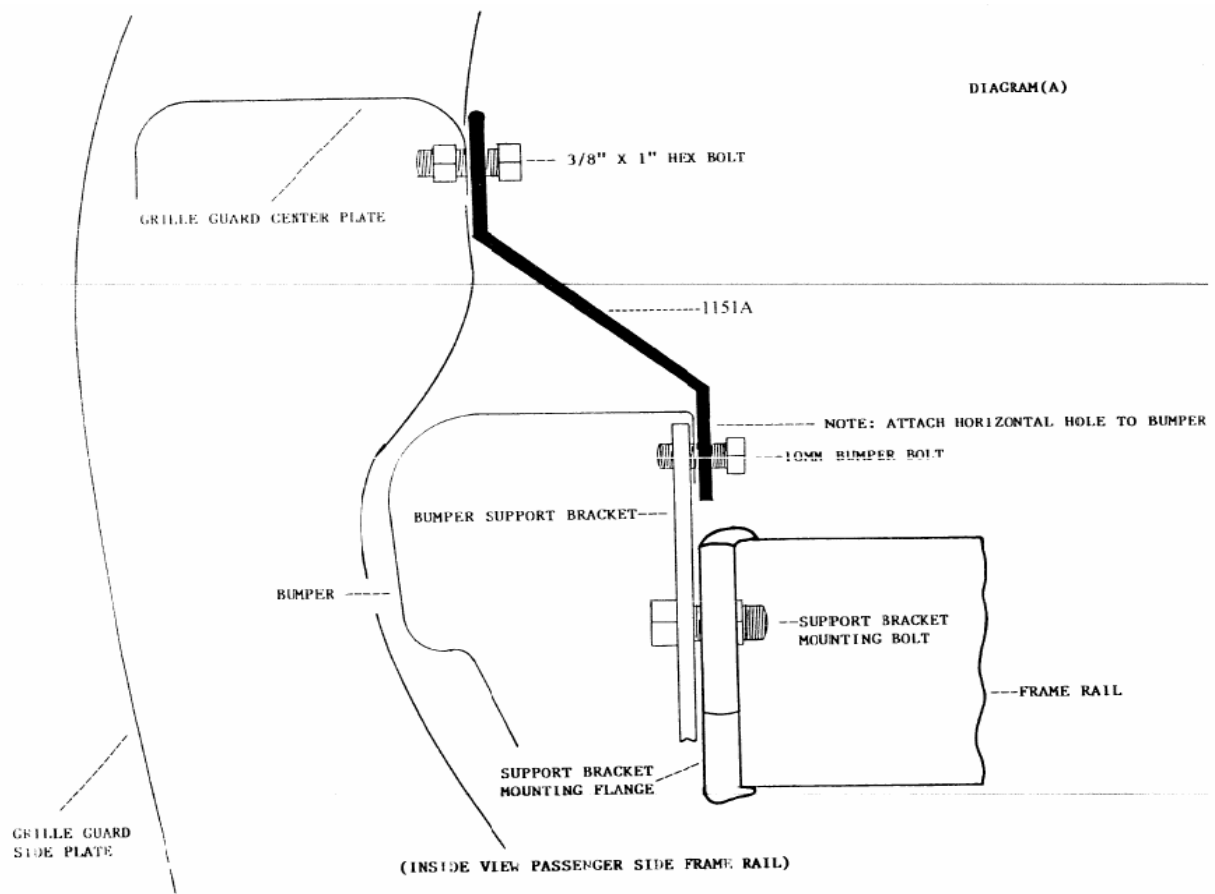

FRONT VIEW PASSENGER SIDE FRAME BRACKET DIAGRAM (B)

