

GO RHINO! PRODUCTS 3000 SERIES INSTALLATION INSTRUCTIONS

2005 FORD F-250, F-350 SUPER DUTY P/U & EXCURSION 2/4WD PART# 3366B, 3366C **REV.B 06/09**

QTY PARTS DESCRIPTION

1	P200 PLUG KIT
4	1/4" X 1 1/2" HEX BOLTS
6	1/4" HEX NUTS
2	5/16" X 1" HEX BOLTS
2	5/16" LOCK WASHERS
2	5/16" HEX NUTS
4	3/8" X 1" BUTTON HEAD BOLTS
6	3/8" X 1" HEX HEAD BOLTS
4	3/8" X 1 1/4" HEX HEAD BOLTS
10	3/8" LOCK WASHERS

QTY PARTS DESCRIPTION

10	3/8" HEX NUTS
2	3366 SIDE PLATES
1	ST3005 STEP TUBE
1	CP3005 CENTER PLATE
1	TT3005 TOP TUBE
1	1132AD DRIVER SIDE UPPER BRACKET
1	1132AP PASSENGER SIDE UPPER BRACKET
1	1131BD DRIVER SIDE LOWER BRACKET
1	1131BP PASSENGER SIDE LOWER BRACKET
4	1132LP LICENSE PLATE BRACKETS

ASSEMBLY INSTRUCTIONS

STEP 1. BEGIN THE ASSEMBLY BY LAYING THE COMPONENTS OUT ON A PROTECTIVE SURFACE.

STEP 2. INSTALL THE TUBE CONNECTORS FROM THE P200 PLUG KIT INTO THE TOP TUBE.

STEP 3. POSITION THE STEP TUBE, CENTER PLATE AND TOP TUBE BETWEEN THE GRILLE GUARD SIDE PLATES.

STEP 4. ATTACH THE STEP TUBE TO THE SIDE PLATES USING THE 3/8" X1" BUTTON HEAD BOLTS, THE CENTER PLATE USING THE 3/8" X 1" HEX HEAD BOLTS, WASHERS, AND NUTS, AND TOP TUBE USING THE P200 PLUG KIT.

STEP 5. ALIGN THE GRILLE AND BRUSH GUARD ASSEMBLY AND TIGHTEN ALL NUTS AND BOLTS.

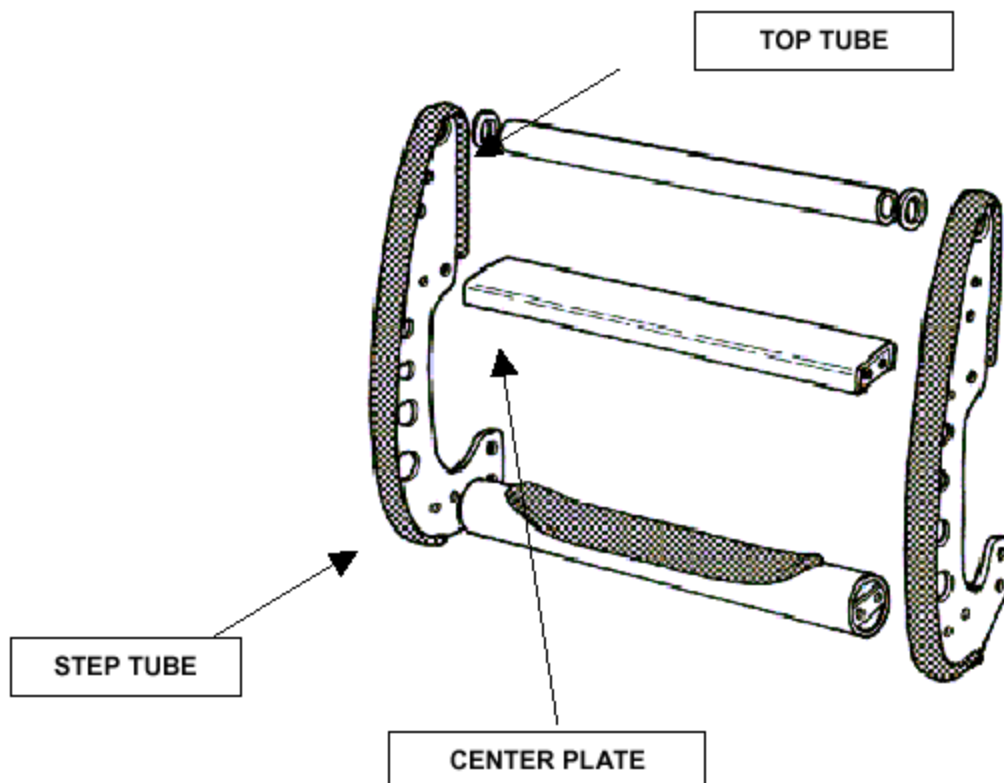

INSTALLATION INSTRUCTIONS

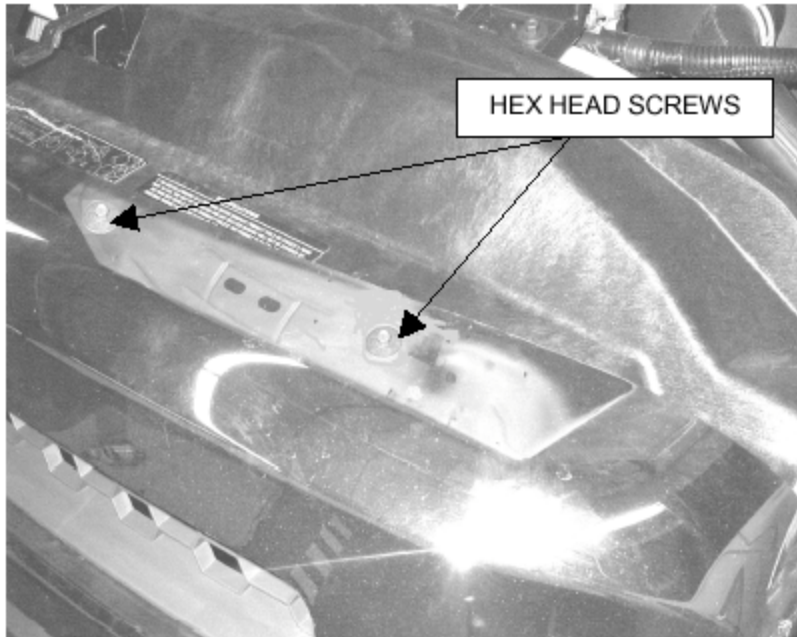

STEP 1. BEGIN THE INSTALLATION BY OPENING THE HOOD AND REMOVING THE (4) HEX HEAD SCREWS FROM THE TOP OF THE GRILLE. UNHOOK THE (4) RETAINING CLIPS AT THE BOTTOM AND REMOVE THE GRILLE FROM THE VEHICLE.

STEP 2. INSTALL THE DRIVER SIDE LOWER MOUNTING BRACKETS. REMOVE THE TWO 12MM BUMPER BOLTS FROM THE FACE OF THE BUMPER, LOCATED NEXT TO THE TOW HOOK.

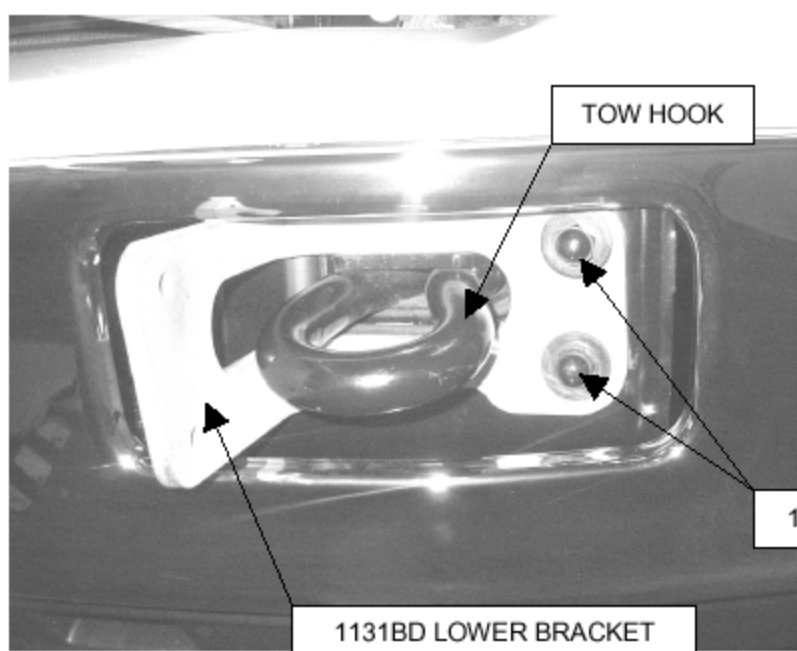
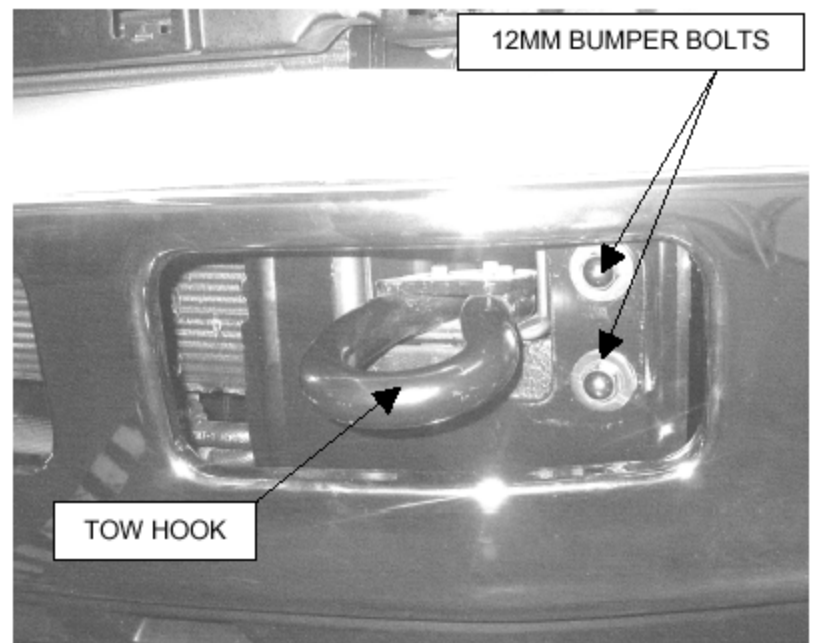

STEP 3. POSITION 1131BD LOWER BRACKET OVER THE TOW HOOK, AND ATTACH TO THE FACE OF THE BUMPER USING THE FACTORY 12MM BUMPER BOLTS.

STEP 4. INSTALL THE DRIVER SIDE UPPER MOUNTING BRACKET. LOCATE THE FLANGE AT THE END OF THE FRAME RAIL SECURING THE BUMPER BRACKET.

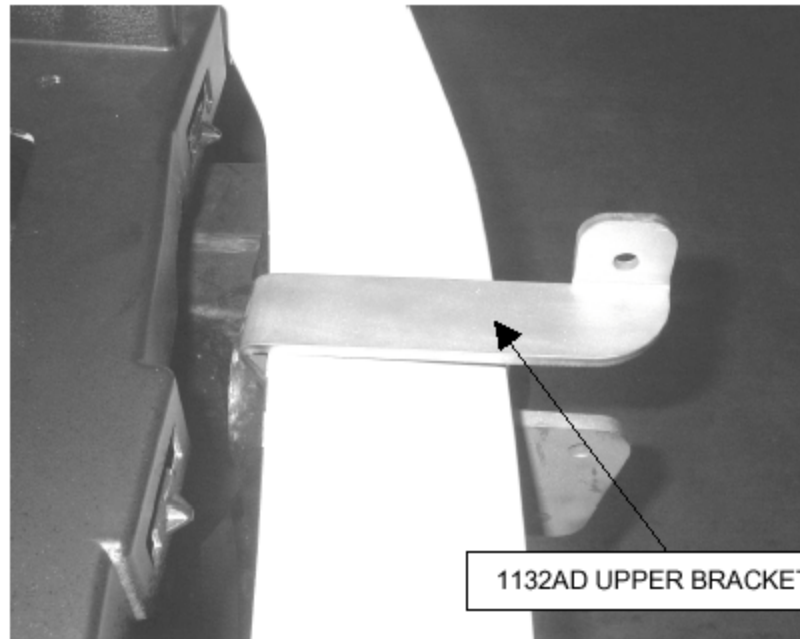
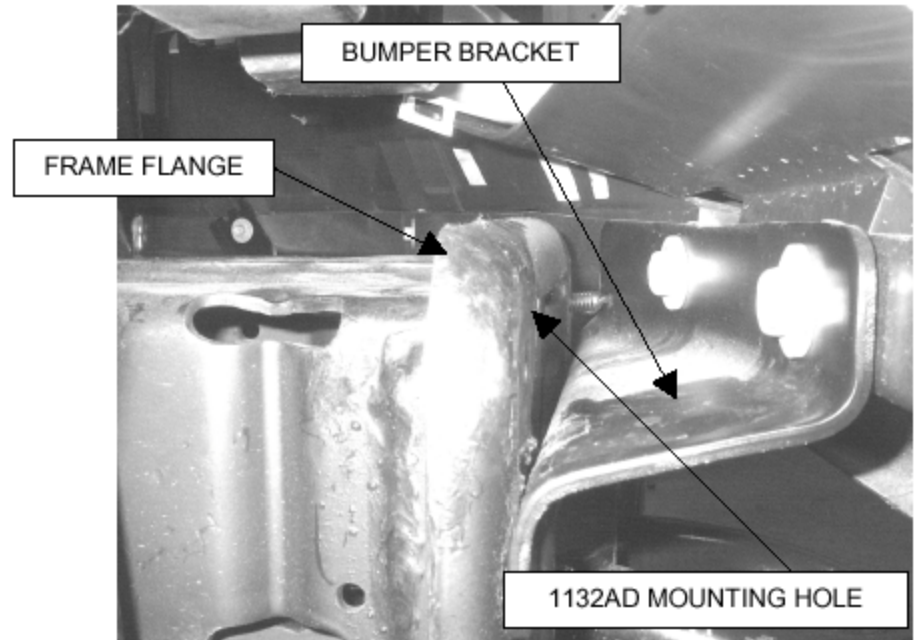

STEP 5. LOCATE THE HOLE IN THE FLANGE, AND ATTACH 1132AD UPPER BRACKET TO THE FRONT OF THE FLANGE, USING THE 5/16" X 1" HEX BOLT, WASHERS AND NUT.

REPEAT THE ABOVE STEPS TO INSTALL THE PASSENGER SIDE BRACKETS.

STEP 6. REMOVE THE (2) PLASTIC RIVETS AND LICENSE PLATE BRACKET FROM THE FRONT BUMPER.

STEP 7. ATTACH THE GRILLE AND BRUSH GUARD ASSEMBLY TO THE OUTSIDE OF THE MOUNTING BRACKETS USING THE 3/8" X 1" HEX BOLTS FOR THE UPPER BRACKETS AND THE 3/8" X 1 1/4" HEX BOLTS FOR THE LOWER BRACKETS. ALIGN THE GRILLE AND BRUSH GUARD ASSEMBLY WITH FRONT OF VEHICLE AND TIGHTEN ALL NUTS AND BOLTS.

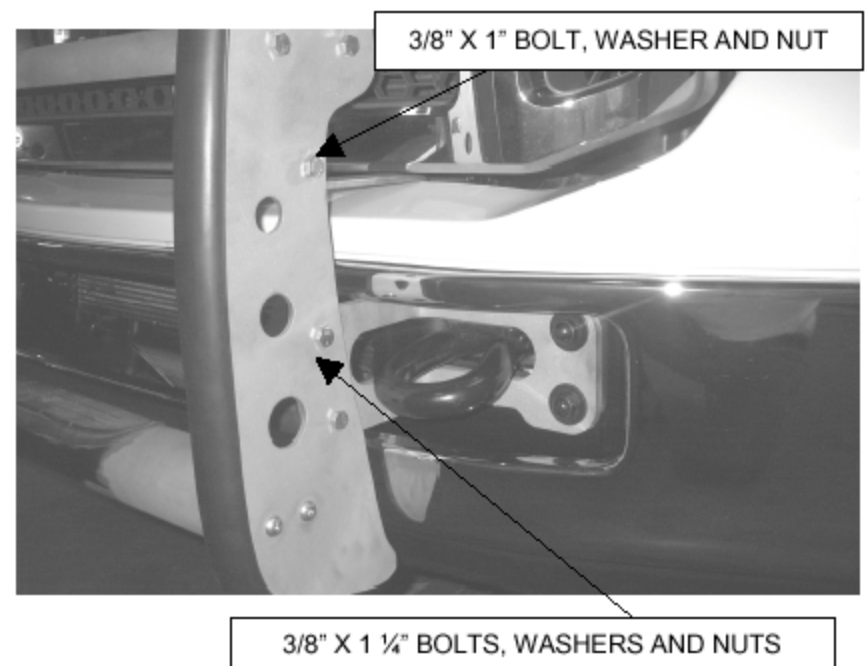

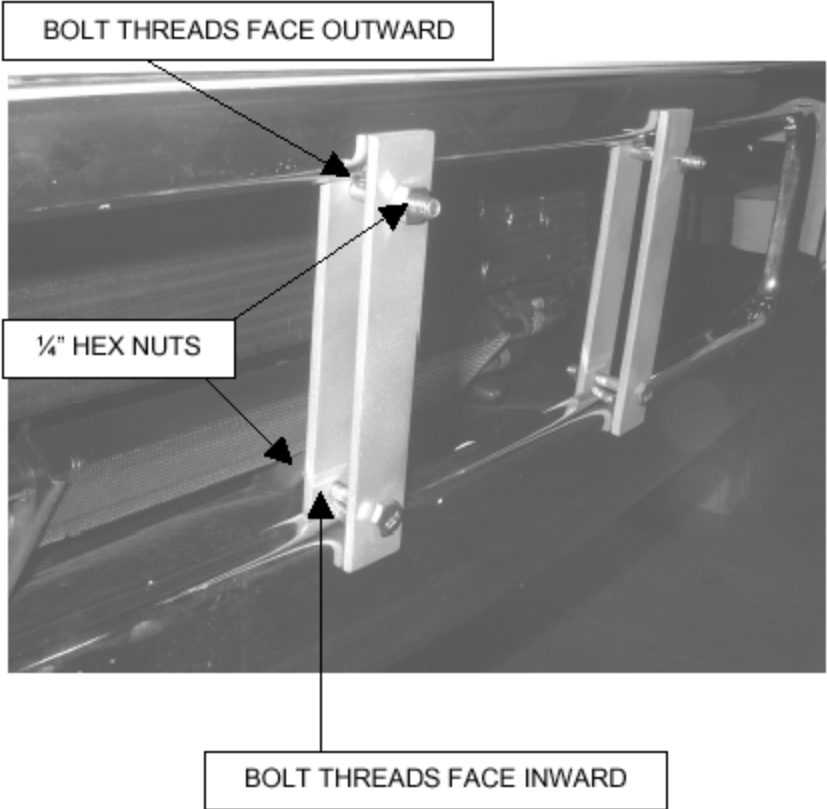

STEP 8. IF YOUR STATE LAW REQUIRES A FRONT LICENSE PLATE, ASSEMBLE AND ATTACH THE 1132LP BRACKETS, TO THE FRONT BUMPER USING THE 1/4" X 1 1/2" HEX BOLTS, AND NUTS AS SHOWN.

STEP 9. POSITION THE LICENSE PLATE OVER THE UPPER BOLTS, AND SECURE USING THE 1/4" HEX NUTS.

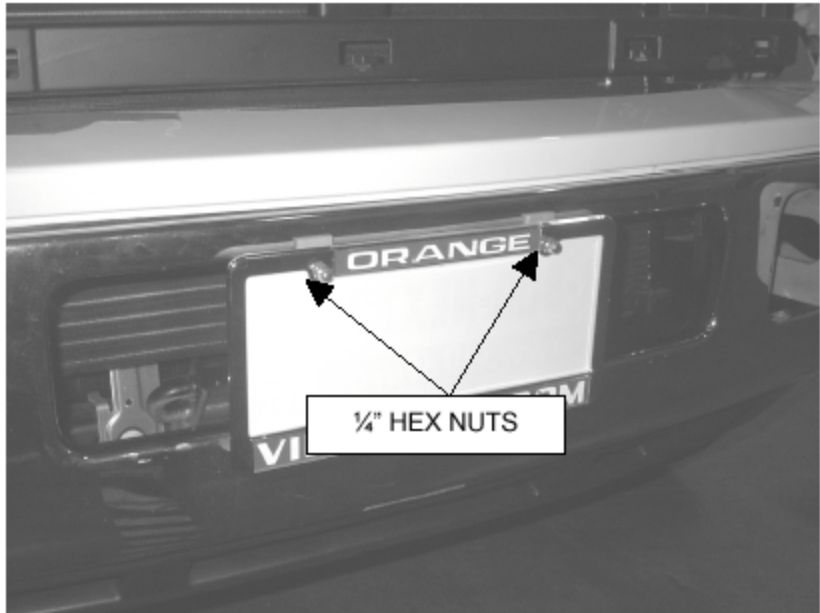

STEP 10. CAREFULLY SLIDE THE GRILLE BETWEEN THE BACK OF THE GRILLE GUARD AND FRONT OF VEHICLE, RE-ATTACH THE GRILLE.