

GO RHINO! PRODUCTS 3000 SERIES INSTALLATION INSTRUCTIONS

99-04 FORD F-250, F-350 SUPER DUTY P/U & EXCURSION 2/4WD PART# 3364MB, 3364MC REV.D 6/09

QTY PARTS DESCRIPTION

2	NYLON FLANGED WASHERS	2	1/4 x 3/4" BUTTON HEAD BOLTS
2	1/4" SOCKET SCREWS	4	5/16 x 1" BUTTON HEAD BOLTS
6	3/8" X 1" BUTTON HEAD BOLTS	4	5/16" LOCK NUT
4	3/8" X 1" HEX HEAD BOLTS	2	5/16 x 1 3/4" FLAT HEAD BOLTS
4	3/8" X 1 1/4" HEX HEAD BOLTS	2	5/16" CONE WASHERS
4	3/8" FLAT WASHERS		
10	3/8" LOCK WASHERS		
10	3/8" HEX NUTS		
1	1131AD DRIVER SIDE UPPER BRACKET		
1	1131AP PASSENGER SIDE UPPER BRACKET		
1	1131BD DRIVER SIDE LOWER BRACKET		
1	1131BP PASSENGER SIDE LOWER BRACKET		

ASSEMBLY INSTRUCTIONS

STEP 1. BEGIN THE ASSEMBLY BY LOOSELY ATTACHING THE BOTTOM STEP TUBE TO THE GRILLE GUARD SIDE PLATES USING THE 3/8" X 1" BUTTON HEAD BOLTS.

STEP 2. INSERT THE FLANGE WASHERS IN THE SIDE PLATES. POSITION THE TOP TUBE BETWEEN THE GRILLE GUARD SIDE PLATES, AND SLIDE THE BRUSH GUARDS THROUGH THE SIDE PLATES, FLANGED WASHERS AND INTO THE TOP TUBE.

STEP 3. POSITION THE CENTER PLATE BETWEEN THE SIDE PLATES, AND ATTACH THE CENTER PLATE TO THE SIDE PLATES AND BRUSH GUARDS USING THE 3/8" X 1" HEX BOLTS, LOCK WASHERS, AND HEX NUTS. NOTE: THREADS MUST FACE OUTWARDS ON BOLTS.

STEP 4. ATTACH THE EUROTUBE TO THE BRUSH GUARDS USING THE 5/16" X 1 3/4" FLAT HEAD SCREWS, AND CONE WASHERS.

STEP 5. ALIGN THE GRILLE AND BRUSH GUARD ASSEMBLY AND TIGHTEN ALL NUTS AND BOLTS. NOTE: SECURE THE TOP TUBE USING THE 1/4" SOCKET SCREWS.

STEP 6. ATTACH THE HEAD LIGHT PROTECTORS TO THE BRUSH GUARDS USING THE 1/4" X 3/4" BUTTON HEAD BOLTS AND TO THE SIDE PLATES USING THE 5/16" X 1" BUTTON HEAD BOLTS AND LOCK NUTS.

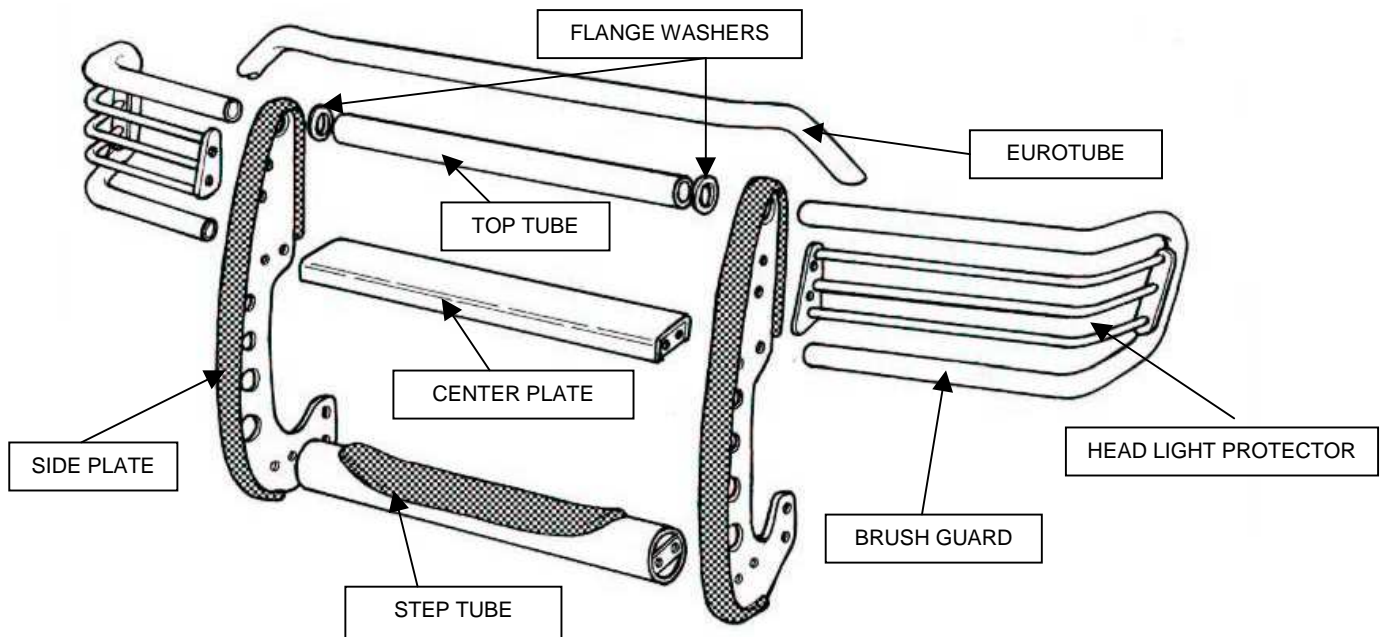

INSTALLATION INSTRUCTIONS

STEP 1. BEGIN THE INSTALLATION BY OPENING THE HOOD AND REMOVING THE (4) PHILLIPS HEAD SCREWS FROM THE TOP OF THE GRILLE. UNHOOK THE (2) RETAINING CLIPS AT THE BOTTOM AND REMOVE THE GRILLE FROM THE VEHICLE.

STEP 2. LOCATE THE 10MM BOLTS THAT CONNECT THE BUMPER TO THE BUMPER SUPPORT BRACKETS. THE BOLTS ARE LOCATED ON THE BACK EDGE AT THE TOP OF THE BUMPER. REACH THROUGH THE OPENING IN THE FACE OF THE BUMPER AND REMOVE THE BOLTS (1) PER SIDE CLOSEST TO THE CENTER OF THE VEHICLE.

STEP 3. LOOSELY ATTACH 1131AD AND 1131AP UPPER BRACKETS TO THE BUMPER SUPPORT BRACKETS USING THE FACTORY 10MM BOLTS.

STEP 4. RE-ATTACH THE GRILLE TO THE FRONT OF THE VEHICLE.

STEP 5. REMOVE THE 12MM BUMPER BOLTS (2) PER SIDE FROM THE FACE OF THE BUMPER.

STEP 6. POSITION 1131BD AND 1131BP LOWER BRACKETS OVER THE TOW HOOKS AND ATTACH TO THE FACE OF THE BUMPER USING THE FACTORY 12MM BUMPER BOLTS.

STEP 7. ATTACH THE GRILLE AND BRUSH GUARD ASSEMBLY TO THE OUTSIDE OF THE MOUNTING BRACKETS USING THE 3/8" X 1" BUTTON HEAD BOLTS FOR THE UPPER BRACKETS AND THE 3/8" X 1 1/4" HEX HEAD BOLTS FOR THE LOWER BRACKETS. ALIGN WITH FRONT OF VEHICLE AND TIGHTEN ALL NUTS AND BOLTS.

