



## Chrome Modular StepGuard

1999 FORD F-150,F-250 EXPEDITION 2/4WD PART NO. 3363MC

### PARTS LIST

2 1/4" SOCKET SCREWS	2 1/2" HOLE X 1/4" THICK 2" O.D. WASHER
2 5/16" X 1" HEX BOLTS	8 1/2" LOCK WASHERS
2 5/16" LOCK WASHERS	4 1/2" FLAT WASHERS
2 5/16" HEX NUTS	8 1/2" HEX NUTS
4 3/8" X 1" HEX BOLTS	2 1312BP BOLT PLATES
4 3/8" X 1" BUTTON HEAD BOLTS	1 1121TD DRIVER SIDE TOP BRACKET
4 3/8" LOCK WASHERS	1 1121TP PASSENGER SIDE TOP BRACKET
4 3/8" HEX NUTS	1 1121D DRIVER SIDE FRAME BRACKET
4 1/2" X 1 1/2" HEX BOLTS	1 1121P PASSENGER SIDE FRAME BRACKET
2 1/2" X 5" HEX BOLTS	2 NYLON FLANGE WASHERS

### ASSEMBLY INSTRUCTIONS

**STEP 1.** ASSEMBLE GRILLE AND BRUSH GUARD ASSEMBLY AS FOLLOWS PER DIAGRAM.

**STEP 2.** PLACE CENTER GUARD ON A FLAT SURFACE FACE DOWN.

**STEP 3.** ATTACH BOTTOM STEP TUBE TO INSIDE OF GRILLE GUARD SIDE PLATES USING 3/8" X 1" BUTTON HEAD BOLTS. DO NOT TIGHTEN.

**STEP 4.** ASSEMBLE BRUSH GUARDS LEFT AND RIGHT BY SLIDING THROUGH SIDE PLATES, FLANGED WASHERS THEN INTO TOP TUBE AS SHOWN.

**STEP 5.** ATTACH EUROTUBE TO BRUSH GUARDS USING 5/16" X 1 3/4" FLAT HEAD SCREWS AS SHOWN IN DIAGRAM INCLUDED WITH EUROTUBE. DO NOT TIGHTEN.

**STEP 6.** POSITION CENTER PLATE BETWEEN SIDE PLATES. ATTACH CENTER PLATE TO SIDE PLATES AND BRUSH GUARDS USING 3/8" X 1" HEX BOLTS, LOCK WASHERS AND HEX NUTS. NOTE: THREADS MUST FACE OUTWARDS ON BOLTS.

**STEP 7.** ATTACH HEAD LIGHT PROTECTORS FIRST TO BRUSH GUARDS USING 1/4" X 3/4" BUTTON HEAD BOLTS THEN TO GRILLE GUARD USING 5/16" X 1" BUTTON HEAD BOLTS AND LOCK NUTS.

**STEP 8.** ALIGN GRILLE AND BRUSH GUARD ASSEMBLY AND TIGHTEN ALL NUTS AND BOLTS.

**STEP 9.** ROTATE TOP TUBE TOWARDS GRILLE AND SECURE USING 1/4" SOCKET SCREWS.

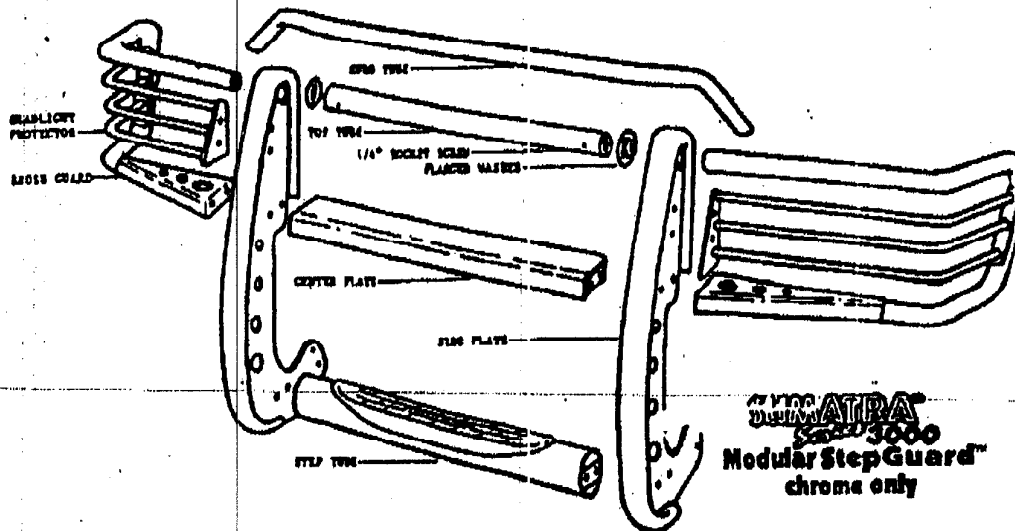

## INSTALLATION INSTRUCTIONS

**NOTE: 2WD MODELS REQUIRE NOTCHING LOWER BUMPER FASCIA**

- STEP 1. IF EQUIPPED, REMOVE TOW HOOKS FROM BOTTOM OF FRAME RAILS.
- STEP 2. POSITION 112BP BOLT PLATE INSIDE OF PASSENGER SIDE FRAME RAIL AS SHOWN IN DIAGRAM (A).
- STEP 3. PLACE 112IP PASSENGER SIDE FRAME BRACKET OVER BOLT PLATE AND SECURE USING 1/2" FLAT WASHER, LOCK WASHER, AND HEX NUT AS SHOWN. DO NOT TIGHTEN.
- STEP 4. ATTACH REAR OF 112IP FRAME BRACKET TO SIDE OF FRAME RAIL USING 1/2" X 5" HEX BOLT, 1/4" THICK X 2" O. D. WASHER, FLAT WASHER, LOCK WASHER AND HEX NUT AS SHOWN. DO NOT TIGHTEN.
- STEP 5. REPEAT ABOVE STEPS FOR DRIVER SIDE FRAME BRACKET.
- STEP 6. REMOVE THE FACTORY 10MM BUMPER BOLT FROM LOCATION SHOWN IN DIAGRAM (B).
- STEP 7. POSITION 1121TP PASSENGER SIDE TOP BRACKET BETWEEN BUMPER AND GRILLE. ATTACH 1121TP BRACKET TO BUMPER BRACKET USING FACTORY 10MM BOLT. AS SHOWN IN DIAGRAM. DO NOT TIGHTEN.
- STEP 8. REPEAT THE ABOVE STEPS FOR 1121TD DRIVER SIDE TOP BRACKET.
- STEP 9. ATTACH THE GRILLE AND BRUSH GUARD ASSEMBLY TO THE OUTSIDE OF THE TOP AND LOWER FRAME BRACKETS USING NUTS AND BOLTS SUPPLIED AS SHOWN IN DIAGRAMS (A) AND (B). DO NOT TIGHTEN.
- STEP 10. ALIGN GRILLE AND BRUSH GUARD ASSEMBLY WITH FRONT OF VEHICLE AND TIGHTEN ALL NUTS AND BOLTS.
- STEP 11. REATTACH TOW HOOKS TO BOTTOM OF FRAME RAILS.

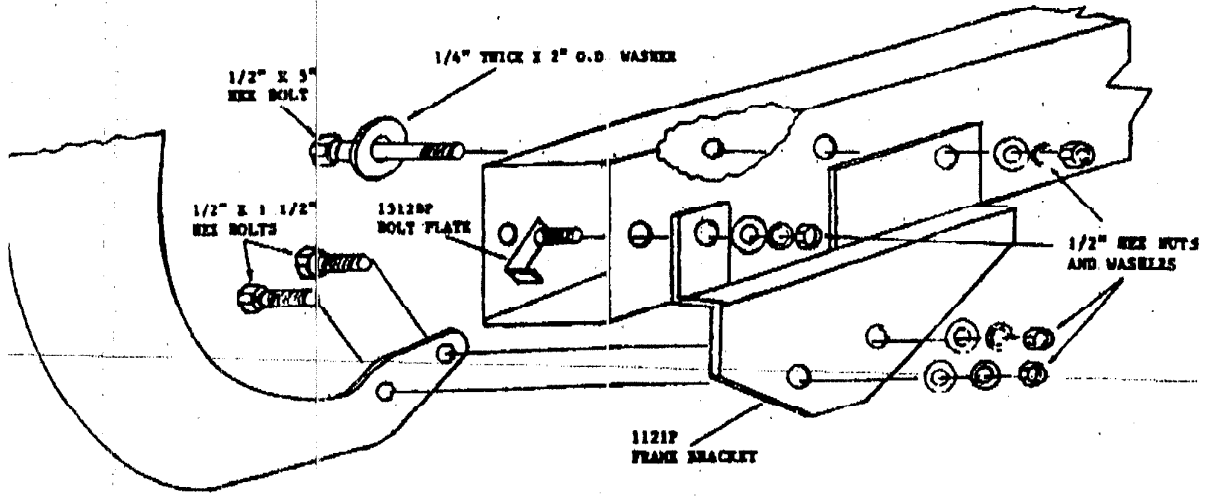

DIAGRAM (A) ASSEMBLY AND INSTALLATION VIEW OF PASSENGER SIDE

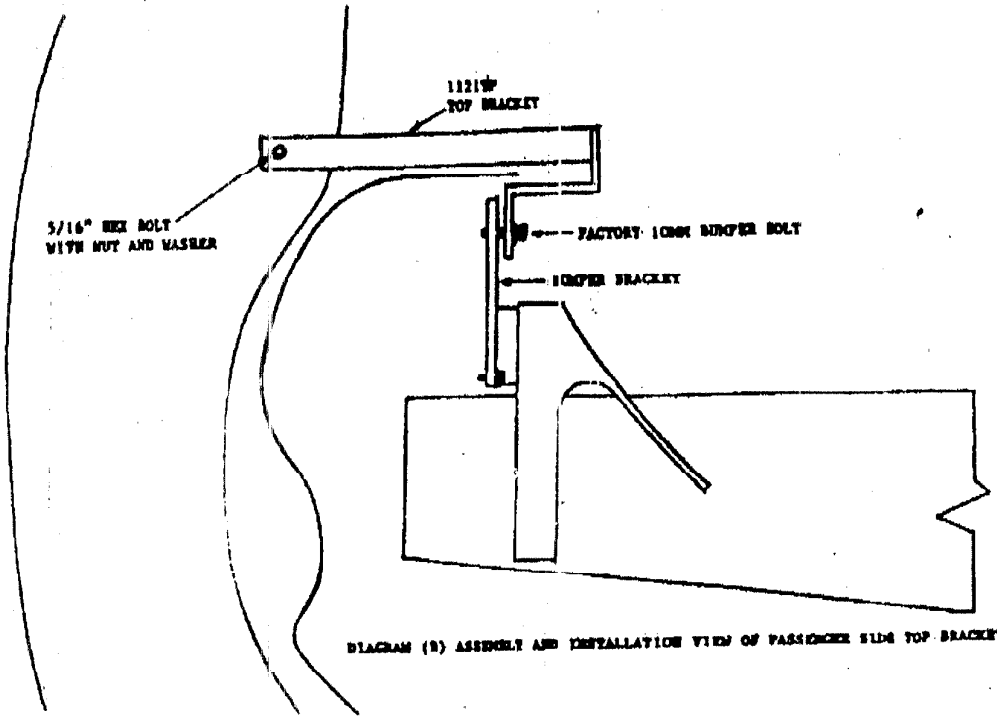

DIAGRAM (B) ASSEMBLY AND INSTALLATION VIEW OF PASSENGER SIDE TOP BRACKET