

## INSTALLATION INSTRUCTIONS

3000 SERIES STEP GUARD (CENTER GRILLE GUARD ONLY)

DODGE RAM 2500 & 3500 2/4WD

PART # 3215 (B-C)



### PACKING LIST

<u>QTY</u>	<u>PARTS DESCRIPTION</u>	<u>QTY</u>	<u>PARTS DESCRIPTION</u>
10	3/8" X 1 1/4" HEX BOLTS	2	3214 SIDE PLATES
10	3/8" LOCK WASHERS	1	ST3160 3" X 35 3/4" BOTTOM STEP TUBE
4	3/8" HEX NUTS	1	TT3534 2" X 35 3/4" TOP TUBE
4	3/8" FLAT WASHERS	1	CP3006 35 3/4" CENTER PLATE

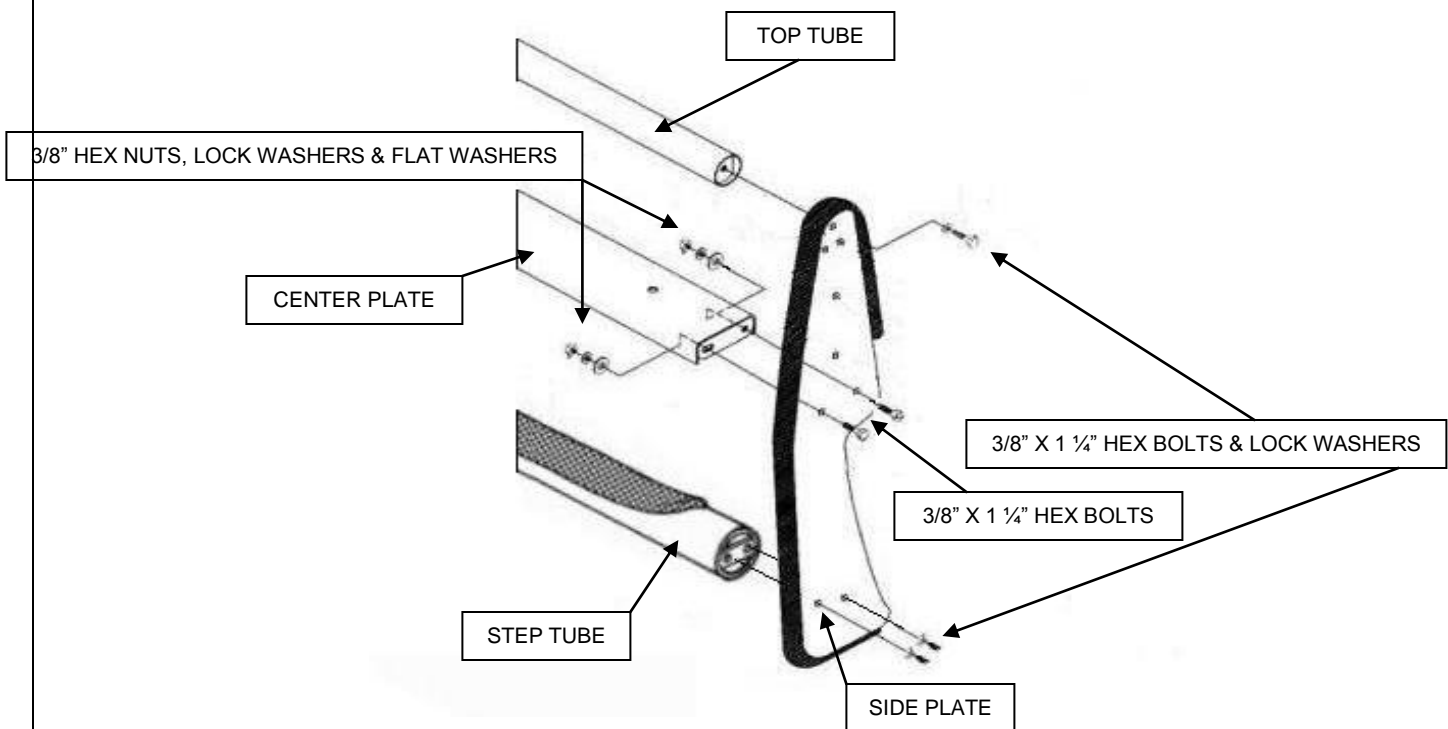

### ASSEMBLY

**STEP 1.** BEGIN THE GRILLE GUARD ASSEMBLY BY LAYING THE COMPONENTS OUT ON A PROTECTIVE SURFACE.

**STEP 2.** POSITION THE GRILLE GUARD SIDE PLATES WITH THE FRONT EDGE DOWN AND THE 2" TOP AND BOTTOM STEP TUBE BETWEEN THE SIDE PLATES.

**STEP 3.** ATTACH THE TOP AND BOTTOM STEP TUBE TO THE SIDE PLATES USING THE 3/8" X 1 1/4" HEX BOLTS AND LOCK WASHERS. DO NOT TIGHTEN.

**STEP 4.** POSITION THE CENTER PLATE BETWEEN THE GRILLE GUARD SIDE PLATES, WITH THE **SLOTTED MOUNTING HOLES** IN THE CENTER PLATE DOWN.

**STEP 5.** INSERT THE 3/8" X 1 1/4" HEX BOLTS THROUGH THE HOLES IN THE SIDE PLATES AND CENTER PLATE, AND INSTALL THE 3/8" FLAT WASHERS, LOCK WASHER AND HEX NUTS. DO NOT TIGHTEN.

**STEP 6.** ALIGN THE GRILLE GUARD ASSEMBLY, AND TIGHTEN ALL NUTS AND BOLTS.

## INSTALLATION INSTRUCTIONS

3000 SERIES STEP GUARD (CENTER GRILLE GUARD ONLY)

DODGE RAM 2500 & 3500 2/4WD

PART # 3215 (B-C)



### PACKING LIST

<u>QTY</u>	<u>PARTS DESCRIPTION</u>	<u>QTY</u>	<u>PARTS DESCRIPTION</u>
2	3/8" X 1 1/4" HEX BOLTS	4	1/2" LOCK WASHERS
2	3/8" FLAT WASHERS	1	2150P PASSENGER LOWER BRACKET
2	3/8" LOCK WASHERS	1	2150D DRIVER LOWER BRACKET
2	3/8" HEX NUTS	1	2151P PASSENGER UPPER BRACKET
4	1/2" HEX NUTS	1	2151D DRIVER UPPER BRACKET
4	1/2" FLAT WASHERS	4	1/2" X 1 1/2" HEX BOLTS

### INSTALLATION

**NOTES: THIS INSTALLATION REQUIRES MODIFYING (NOTCHING) THE LOWER BUMPER VALANCE, ALL MODELS.**

**THIS INSTALLATION REQUIRES MODIFYING (NOTCHING) THE PASSENGER SIDE RADIATOR SHROUD, DIESEL MODELS.**

**STEP 1.** READ THE INSTRUCTIONS COMPLETELY. BEGIN THE INSTALLATION BY REMOVING THE LOWER BUMPER VALANCE. **FIG. #1**

**STEP 2.** REMOVE THE LICENSE PLATE AND MOUNTING BRACKET FROM THE FRONT BUMPER. IF YOUR STATE LAW REQUIRES A FRONT LICENSE PLATE, ATTACH THE LICENSE PLATE DIRECTLY TO THE BUMPER USING THE LOWER HOLES IN THE LICENSE PLATE, AND THE FACTORY SCREWS. **FIG. #2**

**STEP 3.** BEGINNING WITH THE DRIVER SIDE, LOOSEN THE (2) HEX NUTS FROM THE FLANGE BOLT ASSEMBLY THAT SECURE THE BUMPER BRACKETS TO THE SIDE OF THE FRAME RAIL. **FIG. #3**

**STEP 4.** POSITION 2150D LOWER BRACKET OVER THE FLANGE BOLTS AND FINGER TIGHTEN THE NUTS TO SECURE THE BRACKETS. **FIG. #4**

REPEAT THE ABOVE STEPS FOR THE PASSENGER SIDE LOWER BRACKET SIDE.

**STEP 5.** MEASURE AND NOTCH THE BUMPER VALANCE TO FIT WITH THE LOWER BRACKETS. REINSTALL THE BUMPER VALANCE.

**STEP 6.** OPEN THE HOOD, AND LOCATE THE BOLTS SECURING THE FRAME CROSS MEMBER. **FIG. #5**

**STEP 7.** REMOVE THE OUTER BOLT AND ATTACH 2151D UPPER BRACKET TO THE TOP OF THE CROSS MEMBER USING THE FACTORY BOLT. DO NOT TIGHTEN. **FIG. #6**

REPEAT THE PROCEDURE FOR THE PASSENGER SIDE UPPER BRACKET. NOTE: ON DIESEL MODELS, TEMPORALLY REMOVE THE PLASTIC RADIATOR SHROUD TO EXPOSE THE CROSS MEMBER BOLTS.

**STEP 8.** ATTACH THE GRILLE GUARD ASSEMBLY TO THE OUTSIDE OF THE LOWER MOUNTING BRACKETS USING THE 1/2" X 1 1/2" HEX BOLTS, FLAT WASHERS, LOCK WASHERS AND HEX NUTS. DO NOT TIGHTEN. **FIG. #7**

**STEP 9.** ATTACH THE GRILLE GUARD ASSEMBLY TO THE OUTSIDE OF THE UPPER MOUNTING BRACKETS USING THE 3/8" X 1 1/4" HEX BOLTS, FLAT WASHERS, LOCK WASHERS AND HEX NUTS. DO NOT TIGHTEN. **FIG. #8**

**STEP 10.** ALIGN THE GRILLE GUARD ASSEMBLY WITH THE FRONT OF THE VEHICLE AND TIGHTEN ALL NUTS AND BOLTS.

**IMPORTANT: CAREFULLY CLOSE THE HOOD AND CHECK FOR CLEARANCE BETWEEN THE VEHICLES GRILLE AND GRILLE GUARD TOP TUBE. IF NECESSARY, LOOSEN THE MOUNTING BRACKETS AND ADJUST.**

DIESEL MODELS, NOTCH THE PLASTIC RADIATOR SHROUD TO FIT WITH THE PASSENGER SIDE UPPER BRACKET.



FIG #1

LICENSE PLATE BRACKET

LOWER BUMPER VALANCE



FIG #2

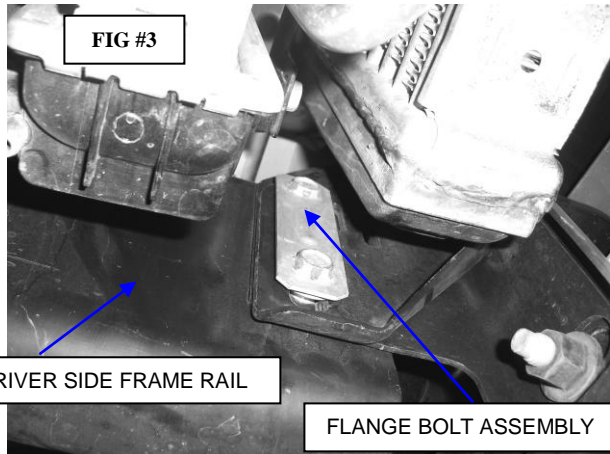

FIG #3

DRIVER SIDE FRAME RAIL

FLANGE BOLT ASSEMBLY

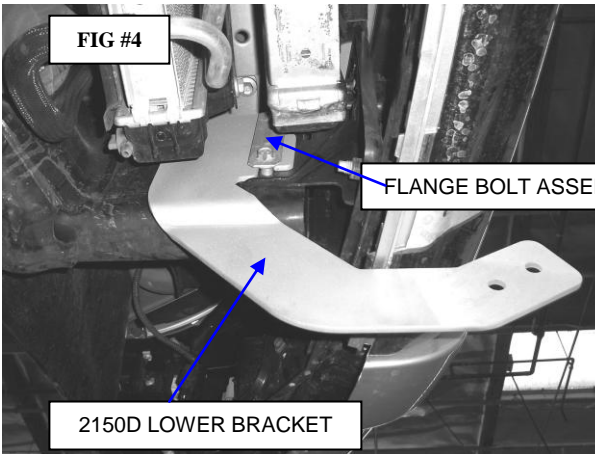

FIG #4

FLANGE BOLT ASSEMBLY

2150D LOWER BRACKET

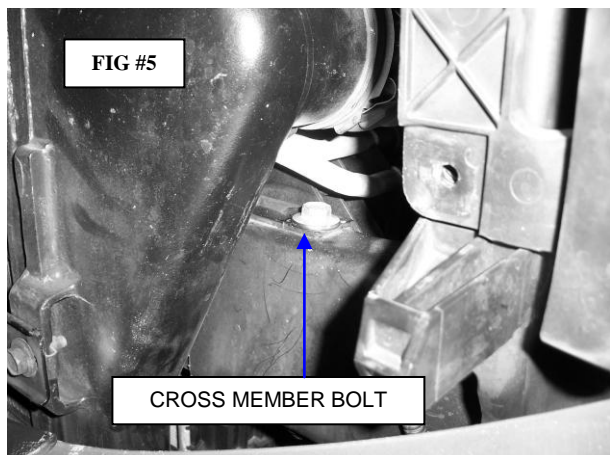

FIG #5

CROSS MEMBER BOLT

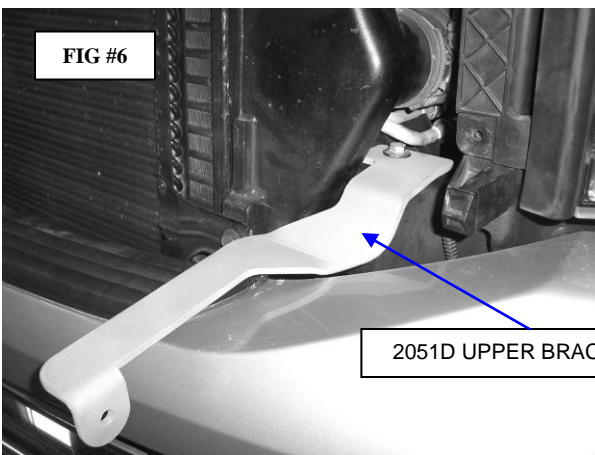

FIG #6

2051D UPPER BRACKET

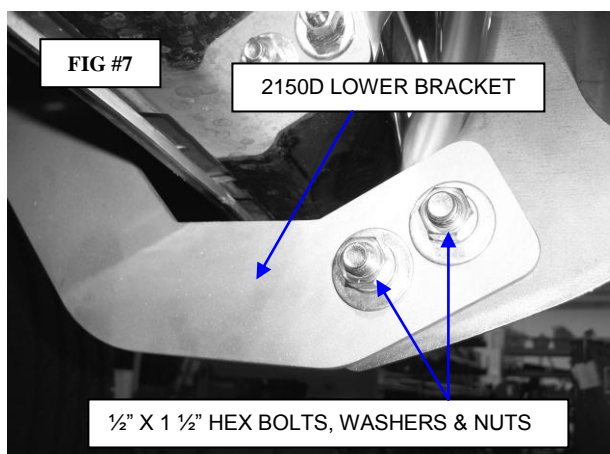

FIG #7

2150D LOWER BRACKET

1/2" X 1 1/2" HEX BOLTS, WASHERS & NUTS

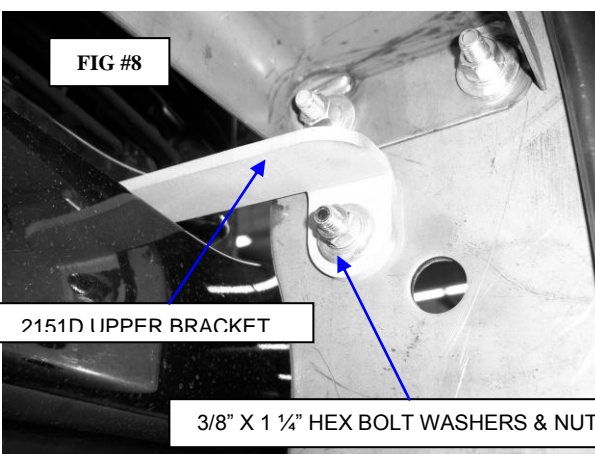

FIG #8

2151D UPPER BRACKET

3/8" X 1 1/4" HEX BOLT WASHERS & NUT