



Innovative Truck Racks!
Two Companies !



One Vision !

3000 SERIES STEPGUARD

GRILLE GUARD ASSEMBLY INSTRUCTIONS

PART NO. 3200B & 3200C 2007 DODGE DURANGO 2/4WD

Do not attempt to install this product on any vehicle other than the one it is designed for and listed above!

PACKING LIST

<u>QTY</u>	<u>PARTS DESCRIPTION</u>	<u>QTY</u>	<u>PARTS DESCRIPTION</u>
10	3/8" X 1 1/4" HEX BOLTS	2	3200 SIDE PLATES
10	3/8" LOCK WASHERS	1	ST3006 3" X 35 3/4" BOTTOM STEP TUBE
4	3/8" HEX NUTS	1	TT3534 2" X 35 3/4" TOP TUBE
4	3/8" FLAT WASHERS	1	CP3006 35 3/4" CENTER PLATE

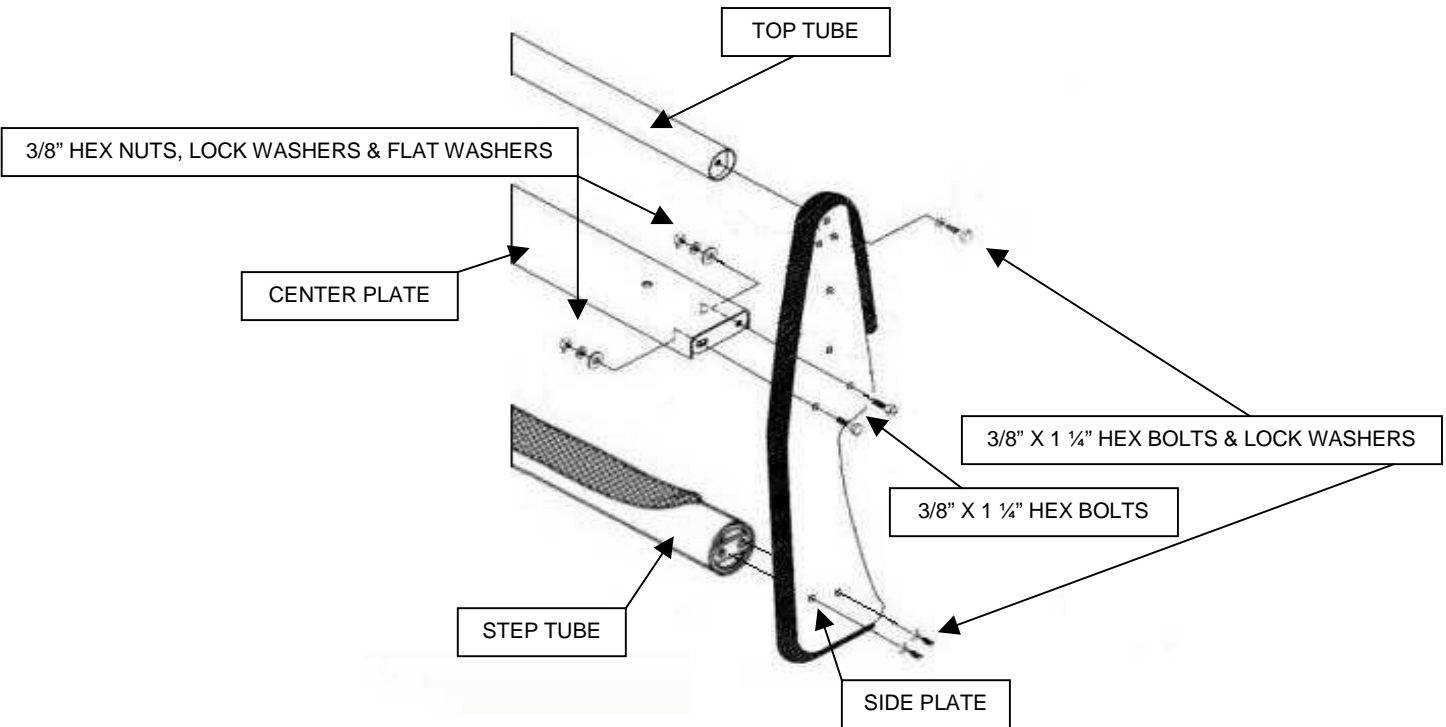

ASSEMBLY

- STEP 1.** BEGIN THE GRILLE GUARD ASSEMBLY BY LAYING THE COMPONENTS OUT ON A PROTECTIVE SURFACE.
- STEP 2.** POSITION THE GRILLE GUARD SIDE PLATES WITH THE FRONT EDGE DOWN AND THE 2" TOP AND BOTTOM STEP TUBE BETWEEN THE SIDE PLATES.
- STEP 3.** ATTACH THE TOP AND BOTTOM STEP TUBE TO THE SIDE PLATES USING THE 3/8" X 1 1/4" HEX BOLTS AND LOCK WASHERS. DO NOT TIGHTEN.
- STEP 4.** POSITION THE CENTER PLATE BETWEEN THE GRILLE GUARD SIDE PLATES, WITH THE **SLOTTED MOUNTING HOLES** IN THE CENTER PLATE DOWN.
- STEP 5.** INSERT THE 3/8" X 1 1/4" HEX BOLTS THROUGH THE HOLES IN THE SIDE PLATES AND CENTER PLATE, AND INSTALL THE 3/8" FLAT WASHERS, LOCK WASHER AND HEX NUTS. DO NOT TIGHTEN.
- STEP 6.** ALIGN THE GRILLE GUARD ASSEMBLY, AND TIGHTEN ALL NUTS AND BOLTS.



Innovative Truck Racks!



Two Companies ! One Vision !

3000 SERIES STEPGUARD

GRILLE GUARD

INSTALLATION INSTRUCTIONS

PART NO. 3200B & 3200C 2007 DODGE DURANGO 2/4WD

Do not attempt to install this product on any vehicle other than the one it is designed for and listed above!

PACKING LIST

<u>QTY</u>	<u>PARTS DESCRIPTION</u>	<u>QTY</u>	<u>PARTS DESCRIPTION</u>
8	1/2" X 1 1/2" HEX BOLTS	1	2001D DRIVER UPPER BRACKET
8	1/2" HEX NUTS	2	2002 LOWER BRACKETS
8	1/2" FLAT WASHERS	1	2000P PASSENGER LOWER BRACKET
8	1/2" LOCK WASHERS	1	2000D DRIVER LOWER BRACKET
1	2001P PASSENGER UPPER BRACKET		

INSTALLATION

NOTE: THIS INSTALLATION REQUIRES REMOVAL OF THE FACTORY TOW HOOKS AND REMOVAL OR NOTCHING THE LOWER BUMPER VALANCE. READ THE INSTALLATION INSTRUCTIONS COMPLETELY BEFORE YOU BEGIN.

STEP 1. (NOTCHING THE LOWER BUMPER VALANCE) BEGINNING WITH THE DRIVER SIDE, MEASURE 17 1/2" AND 18" FROM THE CENTER OF THE VALANCE, AND SCRIBE TWO VERTICAL LINES. AT THE TOP SCRIBE A HORIZONTAL LINE. CUT AND REMOVE THE SECTION BETWEEN THE LINES. **FIG #1**

STEP 2. LOCATE AND REMOVE THE BODY MOUNTING BOLT FROM THE BOTTOM OF THE FRAME, AND THE HEX NUTS THAT SECURE THE BUMPER BRACKET TO THE FRAME. **FIG #2**

STEP 3. ASSEMBLE (1) 2002 AND 2000D LOWER BRACKETS USING (2) 1/2" X 1 1/2" HEX BOLTS, FLAT WASHERS, LOCK WASHERS AND HEX NUTS. POSITION THE BRACKET ASSEMBLY OVER THE STUDS, AND LOOSELY ATTACH THE ASSEMBLY TO THE FRAME USING THE FACTORY NUTS AND BOLT AS SHOWN. **FIG #3**

REPEAT THE ABOVE STEPS TO INSTALL THE PASSENGER SIDE LOWER BRACKETS.

STEP 4. OPEN THE HOOD AND REMOVE THE PLASTIC PIN GRIPS AND PLASTIC RADIATOR SHROUD. **FIG #4**

STEP 5. REMOVE THE (4) BOLTS SECURING THE TOP OF THE GRILLE. **FIG #5**

STEP 6. LOCATE AND REMOVE THE OUTER CROSS MEMBER BOLT. ACCESS THE BOLT BY PULLING OUTWARD ON THE TOP OF THE GRILLE AND REACHING DOWN. **FIG #6**

STEP 7. CUT AND REMOVE THE WEBBING BETWEEN THE (2) LOWER GRILLE LOUVERS. **FIG #7**

STEP 8. POSITION 2001P UPPER BRACKET BETWEEN THE GRILLE LOUVERS AS SHOWN. LOOSELY ATTACH THE BRACKET TO THE CROSS MEMBER USING THE FACTORY BOLT. **FIG #8**

REPEAT THE ABOVE STEPS TO INSTALL THE PASSENGER SIDE UPPER BRACKETS

STEP 9. REMOVE THE 3/8" X 1 1/4" HEX BOLTS AND LOCK WASHERS SECURING THE BOTTOM TUBE OF THE DRIVER AND PASSENGER SIDE BRUSH GUARDS TO THE GRILLE GUARD SIDE PLATES. ATTACH THE GRILLE GUARD ASSEMBLY TO THE LOWER BRACKETS USING (4) 1/2" X 1 1/2" HEX BOLTS, FLAT WASHERS, LOCK WASHERS AND HEX NUTS AND TO THE UPPER BRACKETS USING THE (2) 3/8" BRUSH GUARD BOLTS AND LOCK WASHERS. **FIG. #9 & FIG #10**

STEP 10. ALIGN THE GRILLE GUARD ASSEMBLY WITH THE FRONT OF THE VEHICLE AND TIGHTEN ALL UPPER BRACKET, LOWER BRACKET AND FACTORY NUTS AND BOLTS. REINSTALL THE GRILLE AND RADIATOR SHROUD.

