



3000 SERIES STEPGUARD

GRILLE GUARD ASSEMBLY INSTRUCTIONS

PART NO. 3140B & 3140C 99-04 CHEVY BLAZER 4 WD P/S10 P/U 4WD

Do not attempt to install this product on any vehicle other than the one it is designed for and listed above!

PART LIST

<u>QTY</u>	<u>PART DESCRIPTION</u>	<u>QTY</u>	<u>PART DESCRIPTION</u>
8	3/8 x 1 1/4" HEX BOLT	2	FCB1 SPACER PLATES
4	3/8 x 1" BUTTON BOLT	1	94377D DRIVER SIDE FRAME BRACKET
8	3/8" FLAT WASHER	1	94377P PASSENGER SIDE FRAME BRKT
8	3/8" LOCK WASHER	1	P200 PLUG KIT
8	3/8" HEX NUT		

ASSEMBLY INSTRUCTIONS

READ THE ASSEMBLY AND INSTALLATION INSTRUCTIONS COMPLETELY BEFORE YOU BEGIN.

STEP 1. BEGIN THE GRILLE ASSEMBLY BY LAYING THE COMPONENTS OUT ON A PROTECTIVE SURFACE.

STEP 2. INSTALL THE TUBE CONNECTORS FROM THE P200 PLUG KIT INTO THE TOP TUBE.

STEP 3. POSITION THE STEP TUBE, CENTER PLATE AND TOP TUBE BETWEEN THE GRILLE GUARD SIDE PLATES.

STEP 4. ATTACH THE STEP TUBE TO THE SIDE PLATES USING THE 3/8" x 1" BUTTON BOLTS, THE CENTER PLATE USING THE 3/8" X 1 1/4" HEX HEAD BOLTS, FLAT AND LOCK WASHERS, AND NUTS, AND TOP TUBE USING THE P200 PLUG KIT HARDWARE.

STEP 5. ALIGN THE GRILLE ASSEMBLY AND TIGHTEN ALL NUTS AND BOLTS.

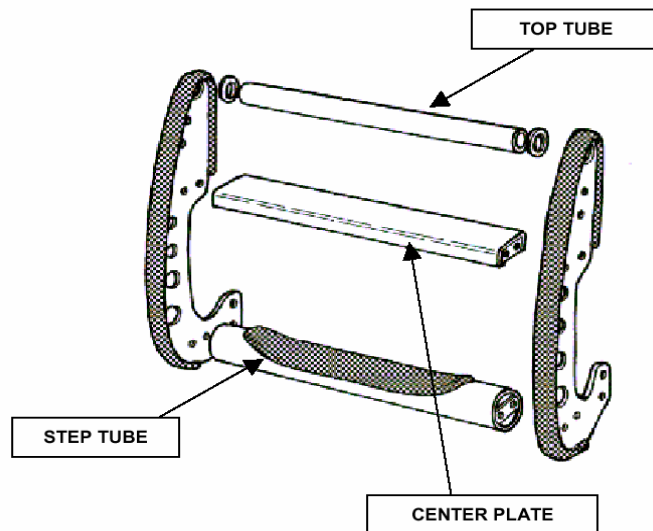

INSTALLATION INSTRUCTIONS

STEP 1. REMOVE MOUNTING BOLTS WHICH SECURE TOW HOOKS TO INSIDE OF FRAME RAILS.

STEP 2. WITH TOW HOOKS IN PLACE, ATTACH DRIVER AND PASSENGER FRAME BRACKETS TO BOTTOM OF FRAME RAILS USING BOLTS REMOVED IN STEP #1. NOTE: PLACE FCB1 SPACER PLATES BETWEEN FRAME BRACKETS AND BOTTOM OF FRAME.

STEP 3. ATTACH GRILLE GUARD ASSEMBLY TO THE OUTSIDE OF FRAME USING 3/8 X 1 1/4" HEX HEAD BOLTS, FLAT WASHERS, LOCK WASHERS AND HEX NUTS. DO NOT TIGHTEN.

STEP 4. ALIGN WITH FRONT OF VEHICLE AND TIGHTEN ALL NUTS AND BOLTS.