

Parts List				
Item	Qty.	Code	Description	Max. Torque
1	1 Piece	53479 - 23169	Pull Pro / Winchbumper	-
2	1 Set	5017602 - 09	Brushguard (driver & passenger)	-
	1 Kit	BRK-53479	Hardware brackets kit	-
3	1 Set	534790CA	Main bracket (driver & passenger)	-
4	1 Set	534790DA	Auxiliary bracket (driver & passenger)	-
5	1 Piece	534794FA	Auxiliary bracket extension (driver & passenger)	-
6	1 Piece	5312361	License bracket	-
7	2 Piece	378312	1/2" Bolt plate	75 Lb.ft
	1 Kit	KTE-53479	Hardware bolts kit	-
8	4 Piece	-	1/2 x 2" Hex head bolt	75 Lb.ft
9	6 Piece	-	1/2" Flat washer	-
10	6 Piece	-	1/2" Lock washer	-
11	2 Piece	-	1/2" Hex nut	75 Lb.ft
12	2 Piece	-	7/16 x 5" Hex head bolt	75 Lb.ft
13	2 Piece	-	7/16" Flat washer	-
14	2 Piece	-	7/16" Hex nut	75 Lb.ft
15	2 Piece	-	7/16" Lock washer	-
16	12 Piece	-	1/2 x 1 1/4" Carriage head bolt	75 Lb.ft
17	12 Piece	-	1/2" Flat washer	-
18	12 Piece	-	1/2" Lock washer	-
19	12 Piece	-	1/2" Hex nut	75 Lb.ft
20	2 Piece	-	3/8 x 1 1/2" Hex head bolt	30 Lb.ft
21	2 Piece	-	3/8" Flat washer	-
22	2 Piece	-	3/8" Lock nut	30 Lb.ft
23	2 Piece	-	1/4 x 1" Hex head bolt	9 Lb.ft
24	2 Piece	-	1/4" Flat washer	-
25	2 Piece	-	1/4" Lock nut	9 Lb.ft

Required Tools (Not included)	
Qty.	Description
1	Socket & wrench 18mm
1	Socket & wrench 3/4"
1	Socket & wrench 9/16"
1	Socket & wrench 3/8"
1	Socket & wrench 11/16"
1	Extension
1	Ratchet
1	Utility knife

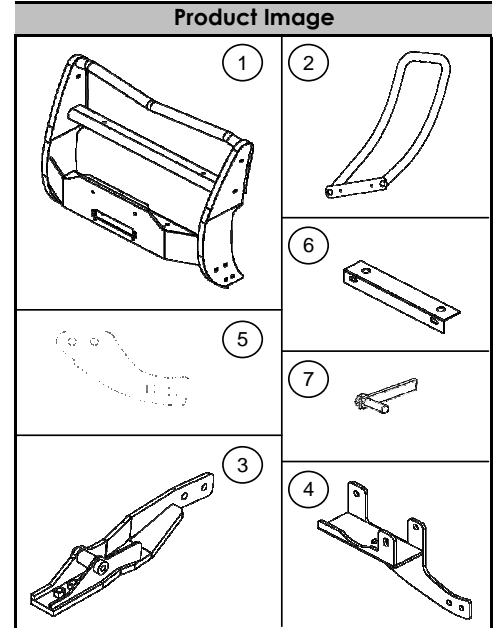

Instructions

- 1.- Before beginning the installation, please read all directions carefully and verify that all necessary hardware is accounted for. If any parts are missing, stop the installation and contact your distributor immediately.
- 2.- To maintain and care this product keep it clean and do not use abrasive cleaners or polish waxes. We recommend to use only non-abrasive automotive wax such as pure carnauba to avoid scratches and rust.
- 3.- The approximate installation time is 60 min.

NOTE 1: This installation requires notching or removal of the lower bumper valance to install the lower frame brackets. If your vehicle is equipped with factory tow hooks they cannot be retained.

- 4.- Beginning with the driver side, measure outward from the center of the lower bumper valance 17 15/16" and 18 7/16" and mark 2 vertical lines. Measure up from the bottom of the valance 2 3/4" and mark a horizontal line. Verify the measurements then use a utility knife and carefully cut and remove the section from the bumper valance. Measure and repeat the process for the passenger side. **SEE PICTURE 1.**

PICTURE 1.

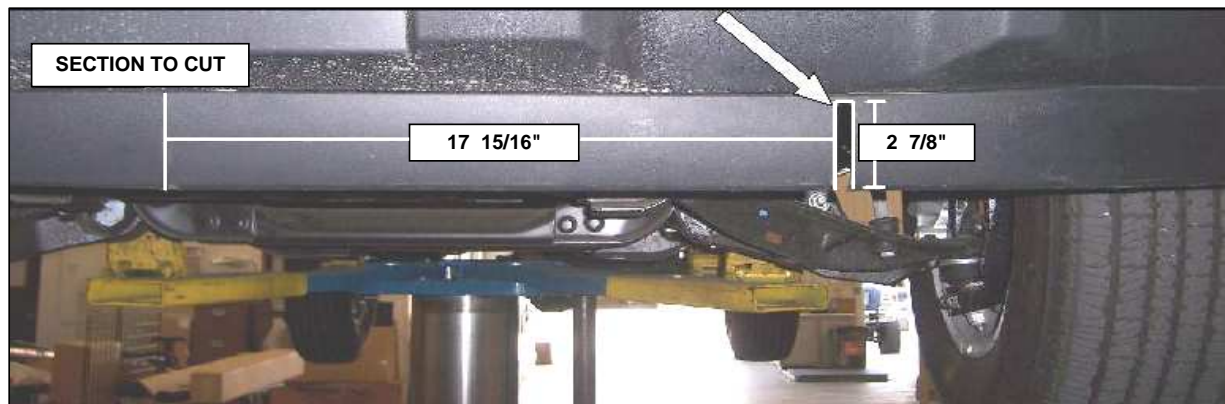

5.- Remove the nut, bolts and tow hook from the driver side frame rail. SEE PICTURE 2 & 3.

PICTURE 2.

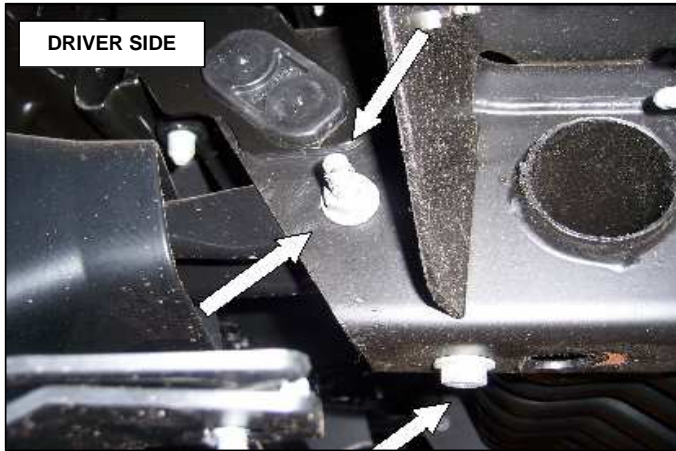

PICTURE 3.



6.- From the front of the vehicle bumper, insert the driver side frame main bracket through the tow hook opening so the leg of the bracket extends into the frame, then align the bracket with the holes in the side and bottom of the frame. SEE PICTURE 4 & 5.

PICTURE 4.



PICTURE 5.

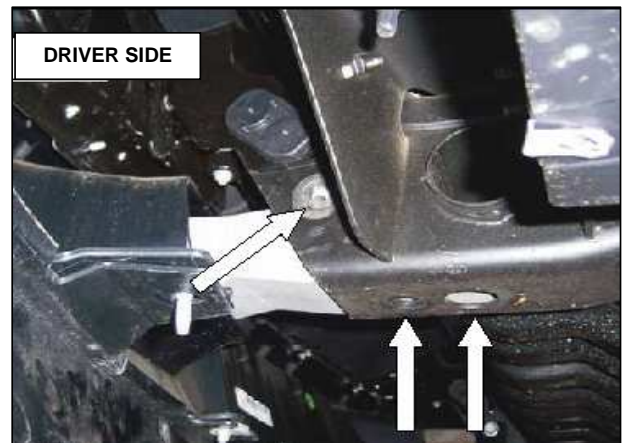

7.- Position the driver side auxiliary bracket against the bottom of the frame, align the main bracket and auxiliary bracket with the holes in the frame and reinstall the tow hook bolt and nut. Leave the bolt and nut loose for final adjustment. SEE PICTURE 6.

NOTE 2: If your vehicle is not equipped with factory tow hooks, attach the brackets to the frame using the 7/16 x 5" hex. head bolt, flat washers and hex. nut supplied.

8.- Attach the auxiliary bracket to the main bracket using the 1/2 x 2" hex. head bolts, 1/2" lock washers and 1/2" flat washers. Leave the bolts loose for final adjustment. SEE PICTURE 7.

PICTURE 6.



PICTURE 7.

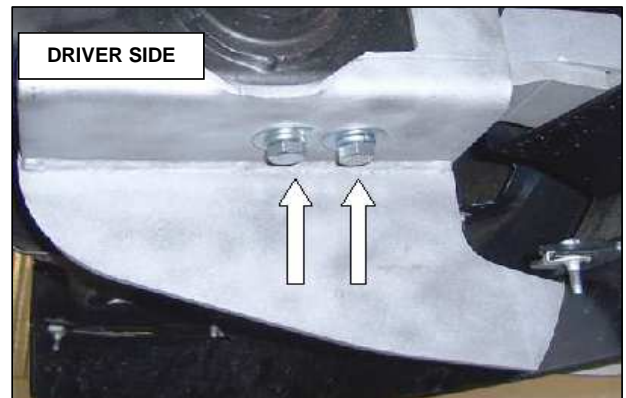

CHEVROLET SILVERADO 2500HD - 3500HD 2011

9.- Remove the plastic skid pan and locate the rectangular opening in the side of the frame. Position one of the 1/2" bolt plates inside the frame with the threads extending out through the auxiliary bracket and install a 1/2" flat washer, 1/2" lock washer and 1/2" hex nut. **SEE PICTURE 8 & 9.**

PICTURE 8.



PICTURE 9.



10.- Attach one of the auxiliary bracket extension to the auxiliary bracket using the 1/2 x 1 1/4" carriage head bolts, 1/2" flat washers and 1/2" nuts. **SEE PICTURE 10.**
Repeat the above steps to install the passenger side brackets.

11.- Position the grille guard to the outside and attach it to the frame brackets using the 1/2 x 1 1/4" carriage head bolts, 1/2" flat washers and 1/2" nuts. **SEE PICTURE 11.**

PICTURE 10.



PICTURE 11.



10.- Attach the brush guards to the grille guard in the upper hole use: 3/8 x 1 1/4" button head bolts, 3/8" flat washers and 3/8" nylon lock nuts, and lower hole use: 3/8 x 1 1/4" button head bolts, preinstall in the central tube. Align the grille and brush guard assembly with the vehicle and tighten all nuts and bolts. **SEE PICTURE 12 & 13.**

11.- If you want to relocate the license plate, secure license bracket to the winch guard plate using: 3/8 x 1 1/4" hex head bolts, 3/8" flat and lock washers, 3/8" hex nuts. Attach license plate on the bracket with 1/4" hardware bolts. **SEE ILLUSTRATION 1.**

12.- Remember to check and retighten the hardware periodically.

PICTURE 12.

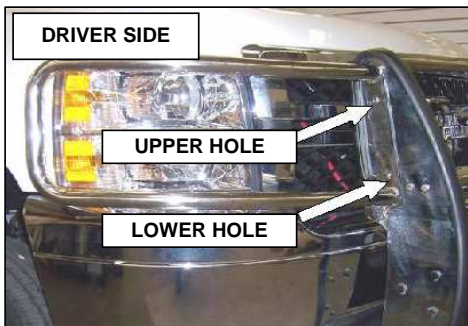

PICTURE 13.



ILLUSTRATION 1.

