

INSTALLATION INSTRUCTIONS
13263 WRANGLER
GMC SIERRA 1500 2007-12 (Exclud. Denali)

Part list:

ITEM	Qty	DESCRIPTION
1	1	GRILLE GUARD
2	1	STEP BAR (INSTALLED)
3	1	BRACKETS SET (BRK-57178)
3.1	2	UPPER BRACKET PC
3.2	2	AUXILIARY BRACKET PC
3.3	1	LOWER BRACKET SET
3.4	1	HARDWARE KIT (KTE-57178)
3.4.1	2	1/2" BLACK NUT
3.4.2	4	1/2 x 1 1/2" BLACK HEX BOLT
3.4.3	8	1/2" BLACK FLAT WASHER
3.4.4	2	1/2" BLACK LOCK WASHER
3.4.5	4	1/2 x 1 1/2" ZINC PLATED HEX BOLT
3.4.6	8	1/2" ZINC PLATED FLAT WASHER
3.4.7	4	1/2" ZINC PLATED LOCK WASHER
3.4.8	4	1/2" ZINC PLATED NUT
3.4.9	2	1/2" BLACK LOCK NUT

Tools required:

DESCRIPTION	Qty
10mm. SOCKET	1
18mm. SOCKET	1
19mm. (3/4") SOCKET	1
21mm. SOCKET	1
19mm. (3/4") WRENCH	1
FLAT SCREW DRIVER	1
RATCHET EXTENSION	1
RATCHET	1
CUTTER	1

Approximated installation time: 40 min.

Img. 1

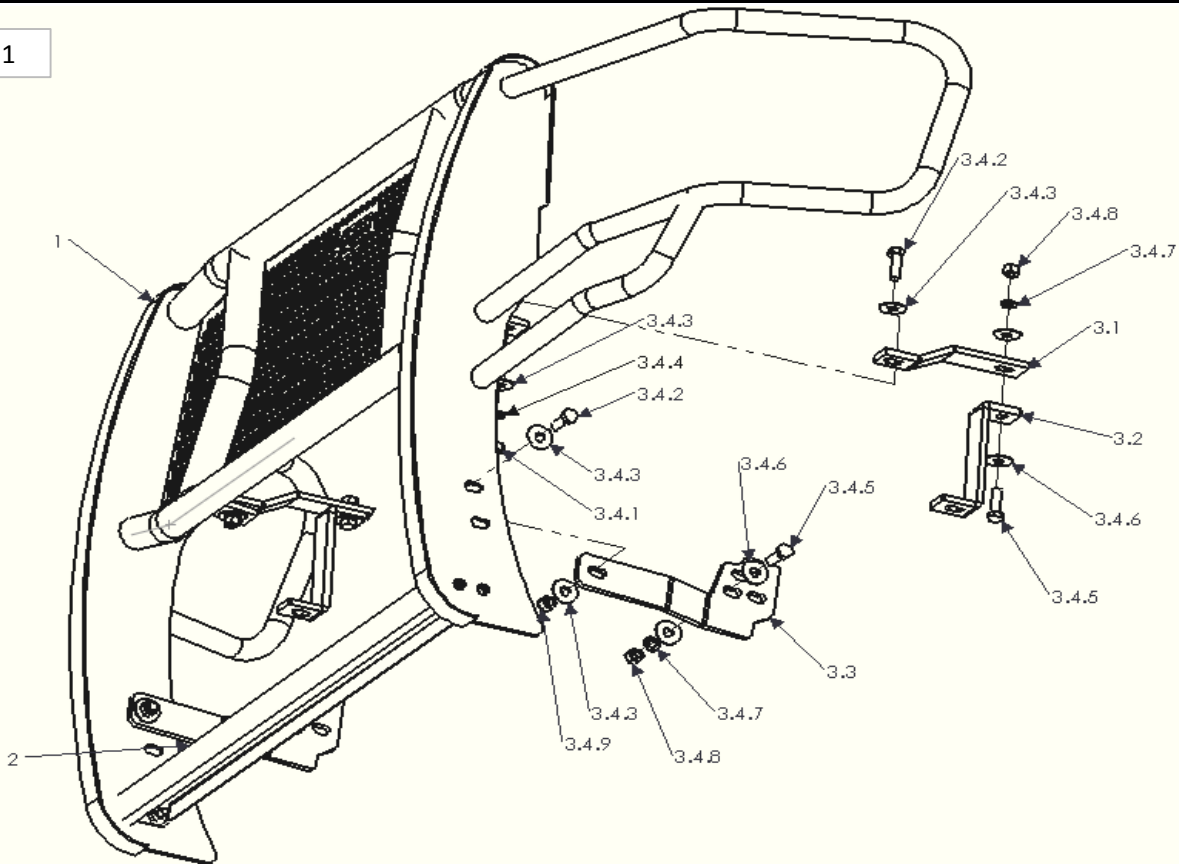

Cleaning and care instructions:

Design:

Quality:

Protect the finish with a non-abrasive automotive wax, (e.g. Pure Carnauba) on a regular basis. The use of any soap, polish, or wax that contains an abrasive is detrimental to the finish, as the compounds scratch the finish and cause.

INSTALLATION INSTRUCTIONS 13263 WRANGLER

1. Carefully read and understand instructions before start installation. If You can not find all the listed parts, please stop installation and call to your distributor to get the missing pieces.
2. Remove the plastic cover over the radiator, taking off the plastic ribbets using a flat screw driver to pull out. (Img. 2)
3. In order to install correctly the lower bracket, it is necessary to cut off the fascia in both sides. (Img. 3)

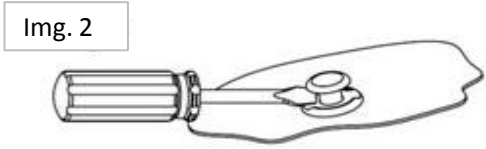

Note. On the driver side it will be necessary to change the orientation of the existing bolt, threaded must faces outboard, see Image 4.

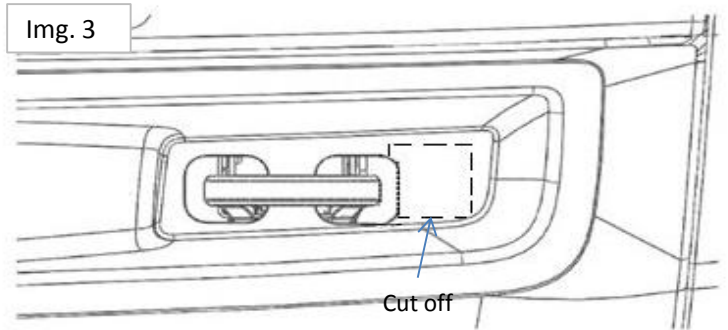

4. Align your accessory and reinstall the plastic cover of the radiator.

5 Fill out your warranty card and place it inside your vehicle.

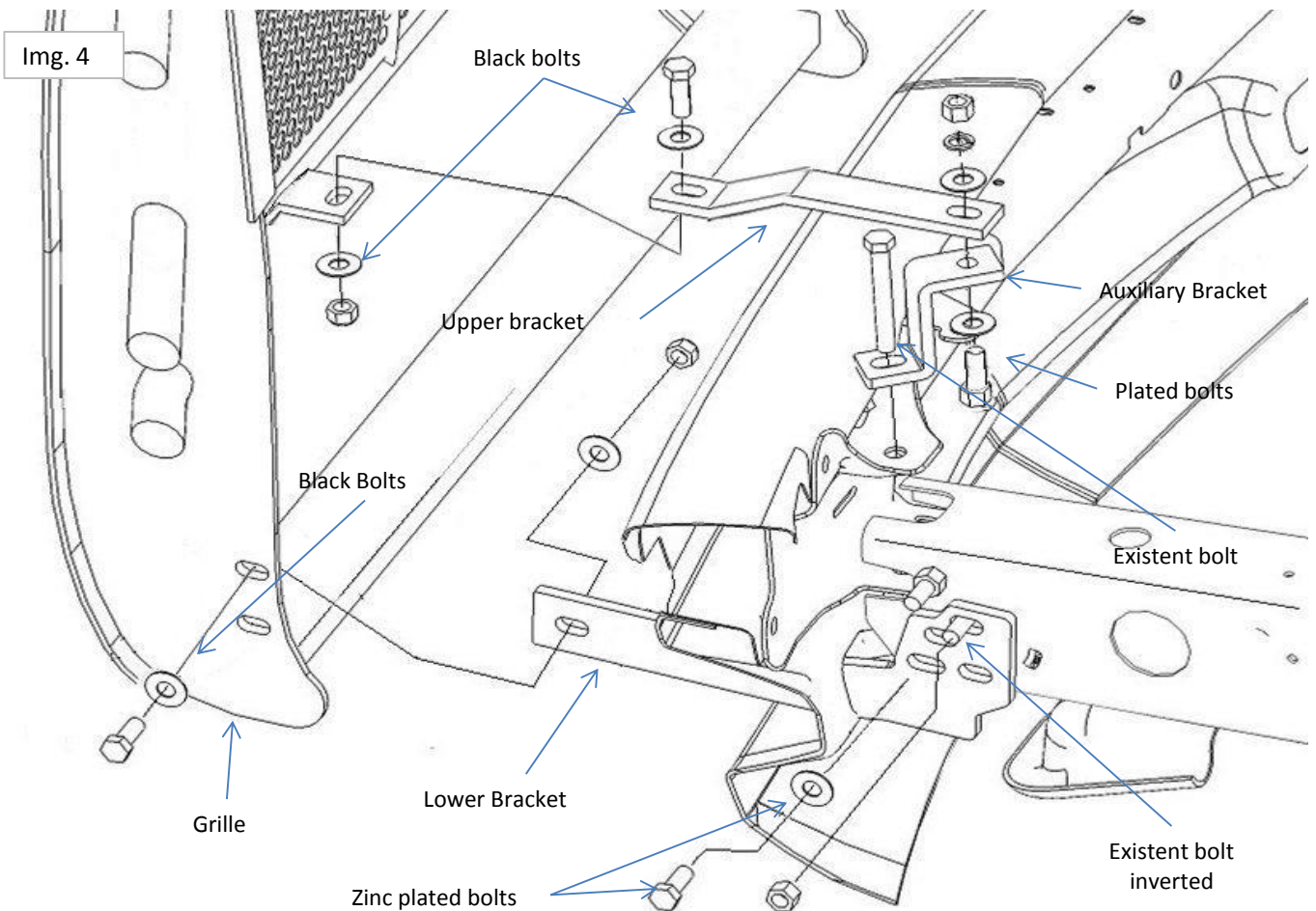

Cleaning and care instructions:

Design:

Quality:

Protect the finish with a non-abrasive automotive wax, (e.g. Pure Carnauba) on a regular basis. The use of any soap, polish, or wax that contains an abrasive is detrimental to the finish, as the compounds scratch the finish and cause.