

INSTALLATION INSTRUCTIONS

OE XTREME BRACKETS

Ford Ranger

6803685

Parts list				
Item	Qty.	Part No.	Description	Torque
1	2	393686AA	Front Bracket	
2	4	393680AA	Center/Rear Bracket	
3	12		M10 x 30mm Hex Bolt	37 Lb Ft
4	12		Flat washer 3/8"	
5	12		Lock washer 3/8"	
6	12		Hex. Bolt 5/16"x1"	18 Lb Ft
7	12		Flat washer 5/16"	
8	12		Lock washer 5/16"	
9	12		Hex nut 5/16"	18 Lb Ft

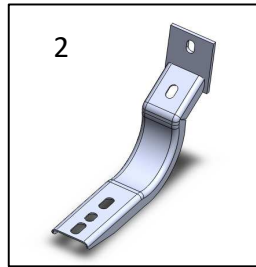
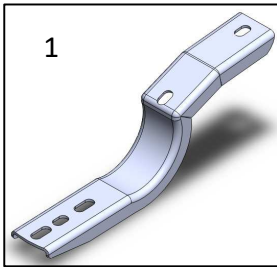

Required tools:

- A. Ratchet
- B. 1/2" & 15mm Socket
- C. 1/2" & 15mm Wrench
- D. Ratchet extension

Before beginning the installations read all instructions carefully and verify that all the hardware is accounted for. If there are any listed part missing please notify your distributor immediately.

To maintain and care this product keep it clean and do not use abrasive cleaners or polish waxes. We recommend using only non-abrasive automotive wax such as pure carnauba to avoid scratches and rust.

The approximated installation time is 30 min.

1. Begin the installation on the driver side. Locate the (3) mounting locations at the front, center and rear of the cab and the threaded holes on the inner rocker panel, (FIGURE 1).

Figure 1



2. At the front mounting location, install one of the front brackets by positioning the bracket over the inner rocker panel and secure to the rocker panel using (2) 3/8" flat washers, (2) 3/8" lock washers and (2) M10 hex bolts. Leave the bolts loose for final adjustment, (FIGURE 2).

Figure 2

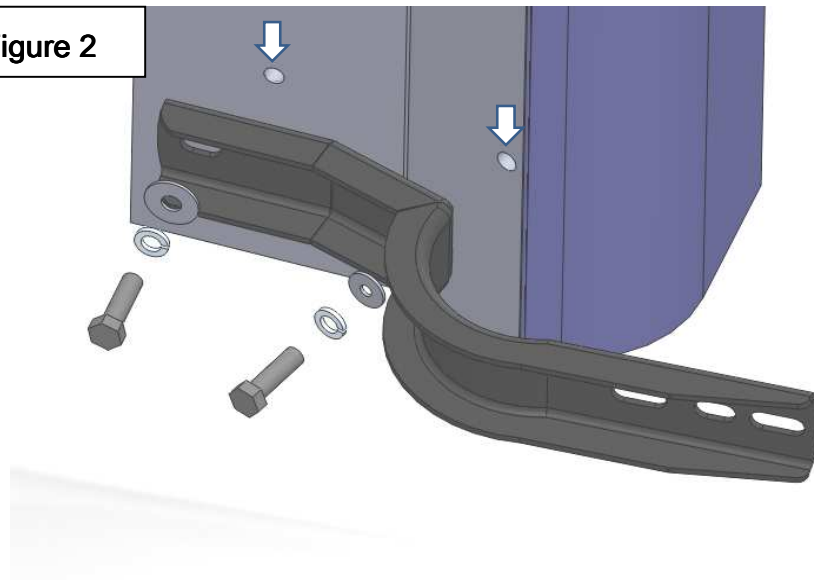

3. Locate the (2) threaded holes on the inner rocker panel at the center and rear of the cab and repeat step 2 to install two of the center/rear brackets using the supplied hardware.

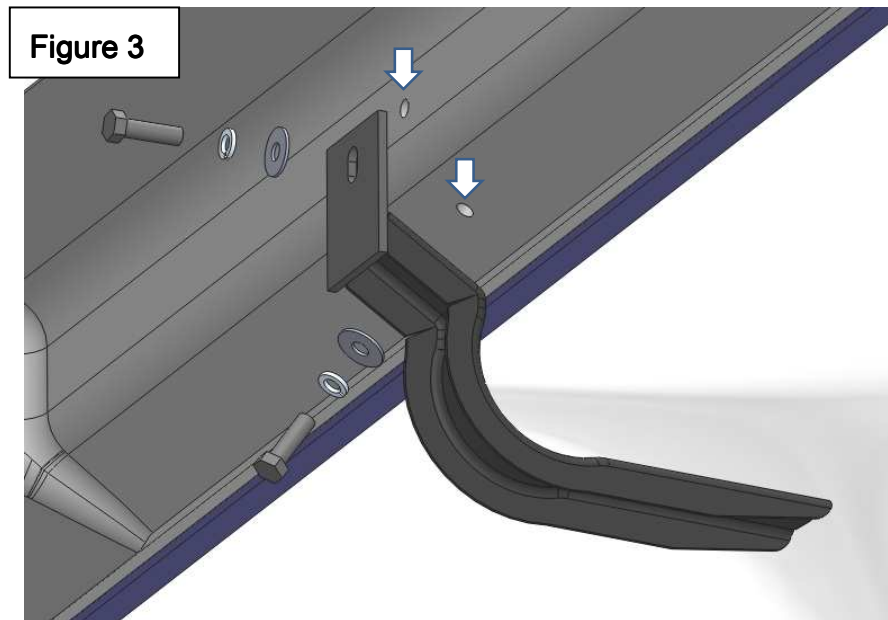

4. If installing 5" XL Widesider Composite side steps, install (6) 5/16" square head bolts (included with side steps) in the aluminum rail on the underside of the side step. Place the side step on top of the mounting brackets so the threads of the square head bolts align and extend through the holes in the brackets. Secure the side step to each bracket using the square head bolts, (2) 5/16" flat washers, (2) 5/16" lock washers and (2) 5/16" hex nuts, (FIGURE 4). Align the side step with the vehicle then tighten all side step and mounting bracket nuts and bolts.



5. If installing Fusion or Platinum widesider (FIGURE 5) place the side step on top of the mounting brackets and position the U-brackets (included with the side steps) inside the open channel in the bottom of the side step. Align the threaded holes in the U-brackets with the holes in the mounting brackets and secure the side step to each bracket using the U-bracket, (2) 5/16" x 1" hex bolts, (2) 5/16" lock washers and (2) 5/16" flat washers. Align the side step with the vehicle then tighten all side step and mounting bracket nuts and bolts.



6. Repeat steps to install the passenger side brackets and side step. Remember to check and re-tighten the nuts and bolts every six months.